

INSTALLATION GUIDE

RESYSTA U-BRACKET CLADDING SYSTEM



1. Introduction

Sec.1 Material Components

Sec.2 Basics

Sec.3 Scope of Profiles

Sec.4 U-Bracket Support
Spacing

2. Installation Guide

Sec.2.1 Vertical Layout

Sec.2.2 Horizontal Layout

3. General Guidelines

Sec.3.1 Expansion Joint

Sec.3.2 General Note

Sec.3.3 Disclaimer

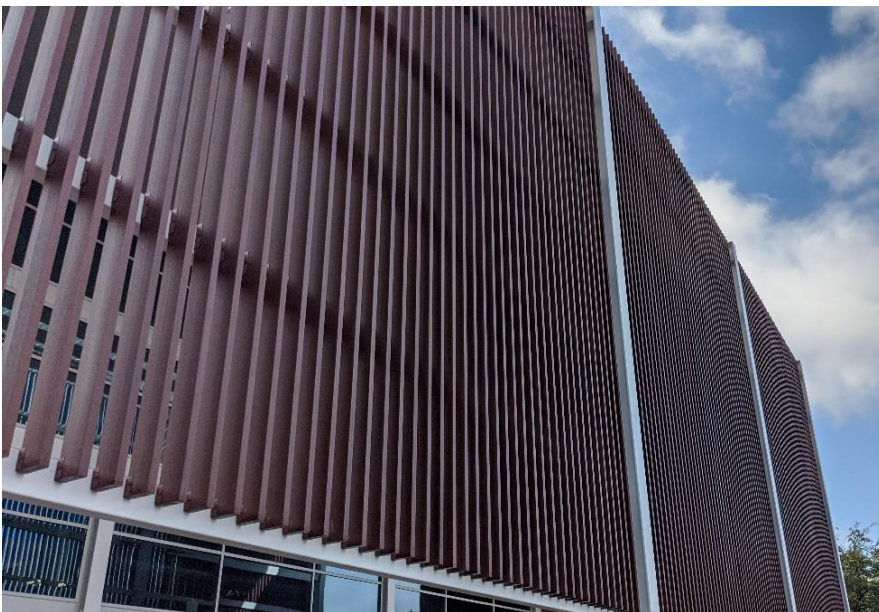

1. Introduction

Resysta is an extremely durable, timber look-alike, building material. It is resistant to damage from the sun, rain, snow and even salt water. Unlike wood, it requires minimal maintenance and is highly resistant to pests, mold and cracks. Unlike other composite materials, it closely resembles the look and feel of natural wood, with a smooth surface finish. Resysta meets most of the future environmentally sustainable material requirements concerning recycled and fully recyclable materials. Resysta is used for its architectural aesthetic, and not for structural support.

SECTION 1 - Material Components

A combination of these three basic raw materials make up the simple components that create Resysta. This innovative material offers designers and architects new creative horizons to utilize its compelling and unique appearance.



Approx. 60% RICE HUSK + Approx. 22% COMMON SALT + Approx. 18% MINERAL OIL

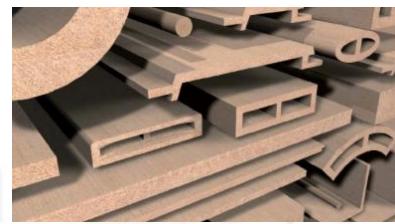

= RESYSTA PRODUCT

SECTION 2 - Basics



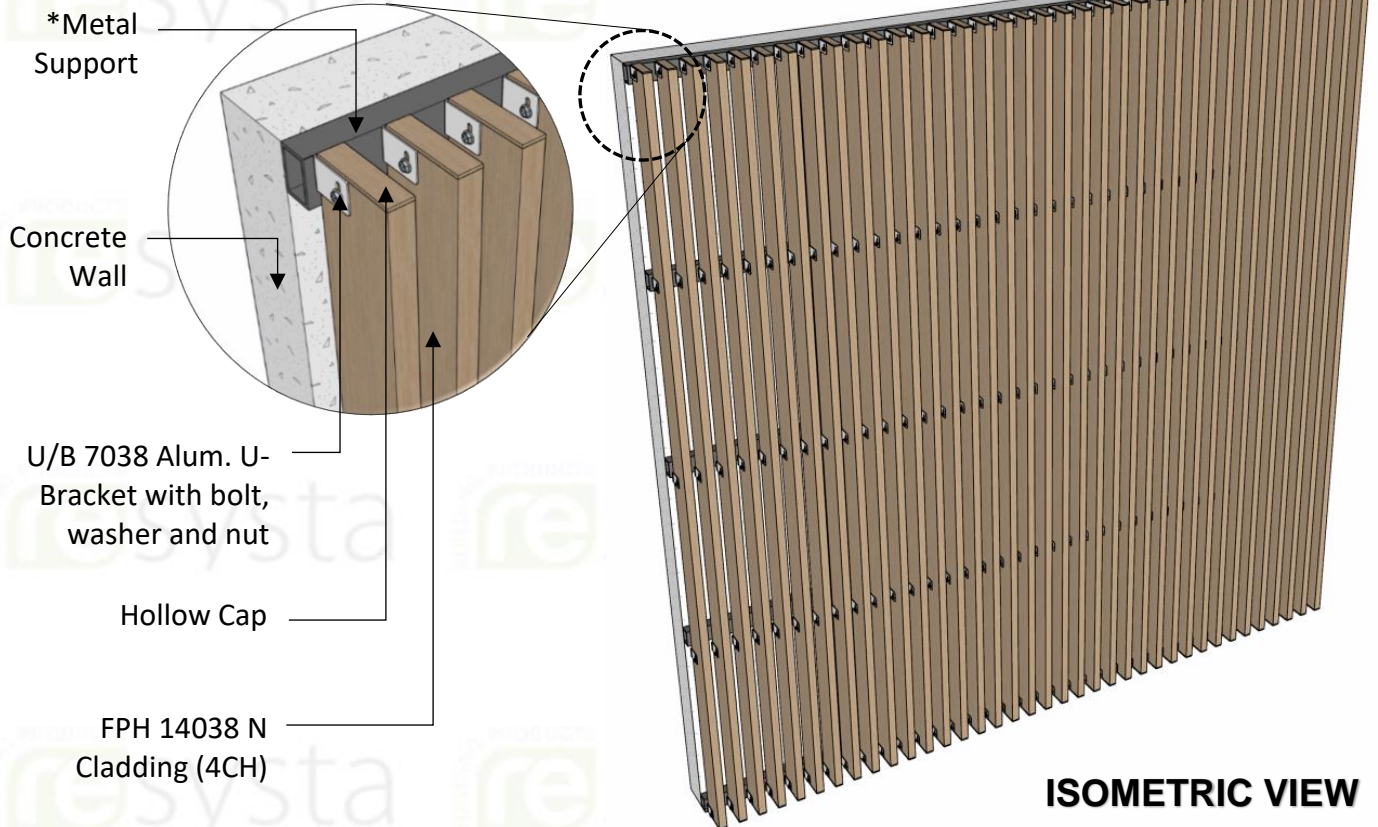





OVERVIEW OF PARTS

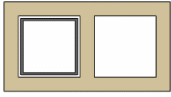

ISOMETRIC VIEW
BASIC PARTS OF U-BRACKET

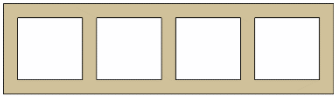
* Metal Structure supplied by 3rd party. brackets can also be bolted directly into concrete walls or other structural panels but would need to be engineered by certified parties.

SECTION 3 - Scope of Delivery

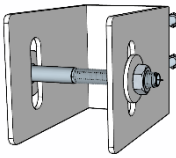
NO.	PRODUCT NAME AND SPECIFICATION	ISOMETRIC VIEW	FRONT VIEW
1	FPH 7038/3.5 70mm x 38mm x 2900mm Resysta Wall Cladding, 2 Channel Thick		
2	FPI 7038/3.5 70mm x 38mm x 2900mm Resysta Wall Cladding, 2 Channel Thick with Aluminum Insert		
3	FPH 14038 N 140mm x 38mm x 2900mm Resysta Wall Cladding, 4 Channel Thick		
4	FPI 14038 N 140mm x 38mm x 2900mm Resysta Wall Cladding, 4 Channel Thick with Aluminum Insert		
5	Hollow Cap		
6	U/B 7038 70mm x 38mm Aluminium U-bracket with bolt, washer and nut		

NOTE: Table above shows products commonly used for wall cladding. To view a complete list of products, please refer to our Resysta brochure or visit our web site <http://www.resysta-asia.com>

SECTION 4 – U-Bracket Spacing

- 1. FPH 7038/3.5**
Resysta Wall Cladding, 2 Channel Thick
70mm x 38mm x 2900mm

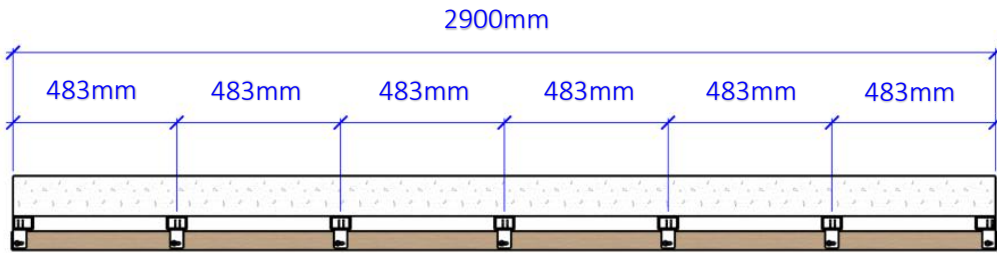

HORIZONTAL LAYOUT (Top View)
483mm U-Bracket Spacing

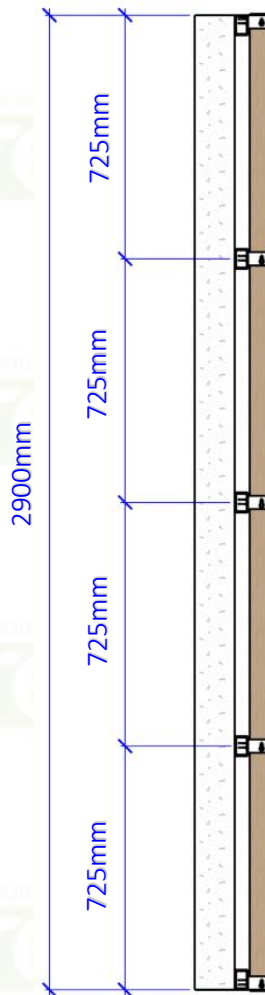

VERTICAL LAYOUT (Side Elevation)
725mm U-Bracket Spacing

2. FPI 7038/3.5

Resysta Wall Cladding, 2 Channel Thick with Aluminum Insert
70mm x 38mm x 2900mm

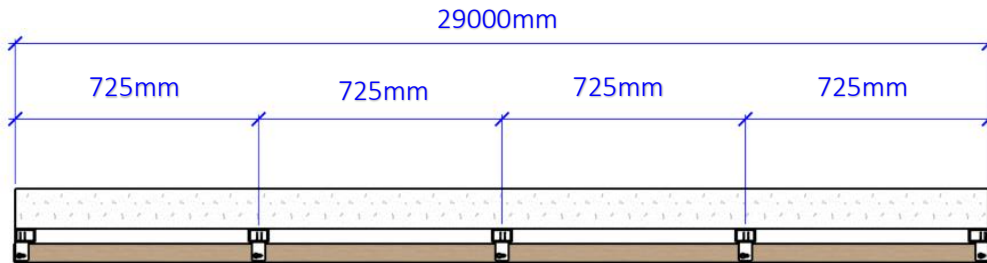

HORIZONTAL LAYOUT (Top View)

725mm U-Bracket Spacing

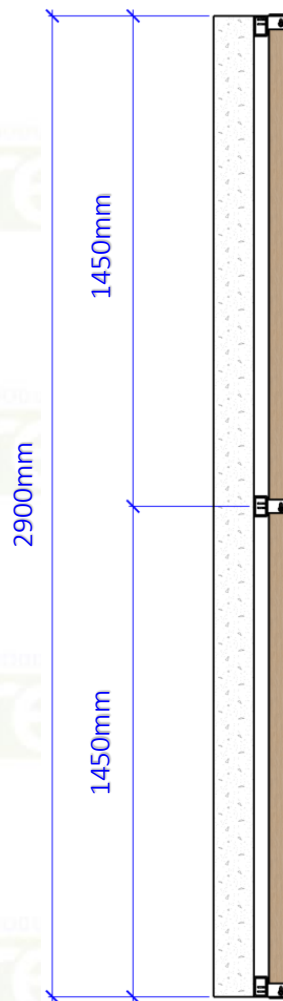

VERTICAL LAYOUT (Side Elevation)

1450mm U-Bracket Spacing

3. FPH 14038 N

Resysta Wall Cladding, 4 Channel Thick
140mm x 38mm x 2900mm

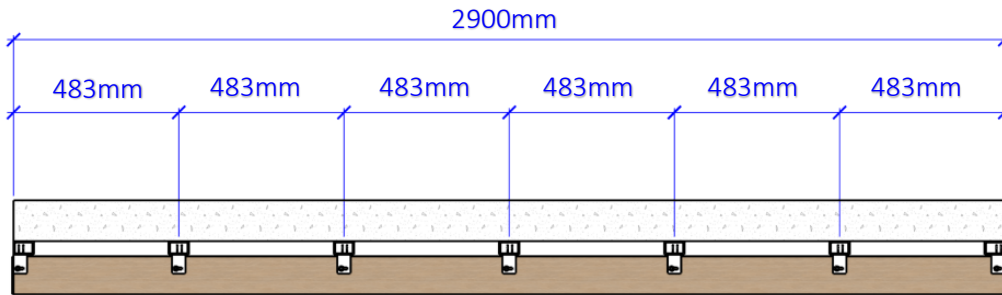

HORIZONTAL LAYOUT (Top View)

483mm U-Bracket Spacing

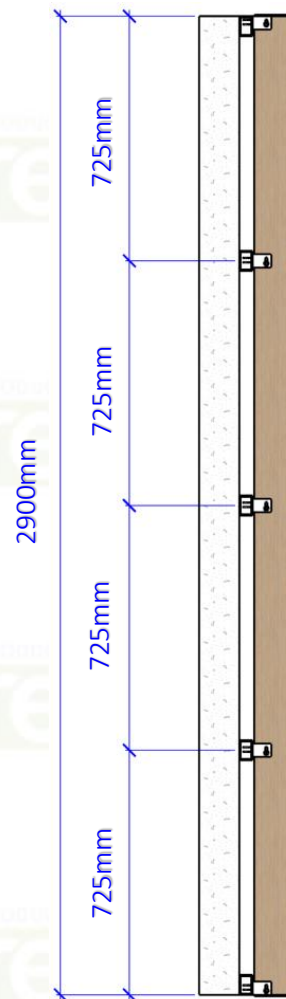

VERTICAL LAYOUT (Side Elevation)

725mm U-Bracket Spacing

4. FPI 14038 N

Resysta Wall Cladding, 4 Channel Thick with Aluminum Insert
140mm x 38mm x 2900mm

(Please note: That FPI 14038 N profile cannot be installed on a horizontal layout.)

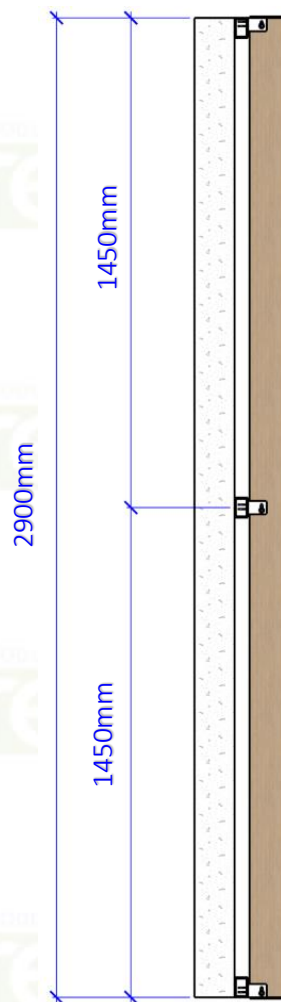

VERTICAL LAYOUT (Side Elevation)
1450mm U-Bracket Spacing

2. Installation Guide

SECTION 2.1 – Vertical Layout

1. Check the layout and designed direction of the cladding to be installed; whether it is horizontal, vertical or depends on the design requirements.
2. Ensure that the metal support is 100% levelled and plumb before installing the aluminium U-bracket on the metal support.
3. The location of the metal support will vary depending on what type of Resysta Cladding is being used. Please refer the spacing of the metal support and U-Bracket on 1.4 U-Bracket Spacing.

PROCEDURES for FPH 14038 N Vertical Layout

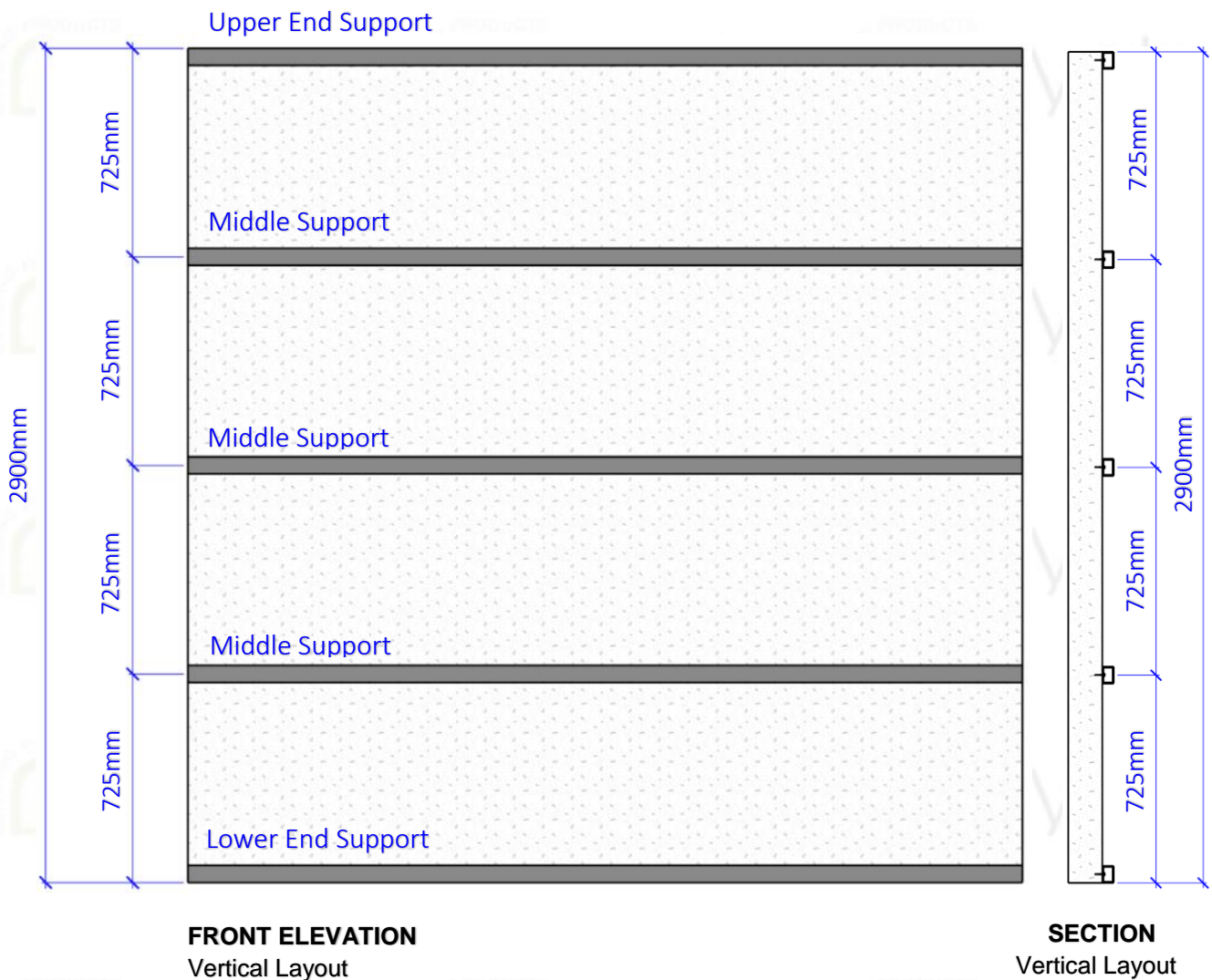

- Install the first U-bracket vertically at the corner end of the metal support flashed and levelled, followed by a U-bracket in every 725mm center of horizontal metal support.

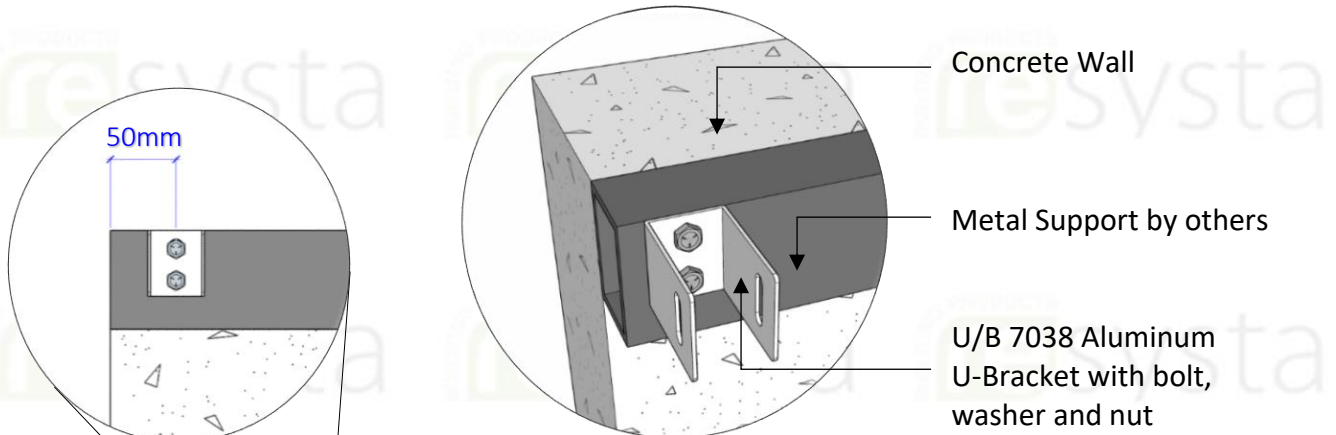

DETAIL 1
Upper End U-Bracket

ELEVATION
Upper End U-Bracket

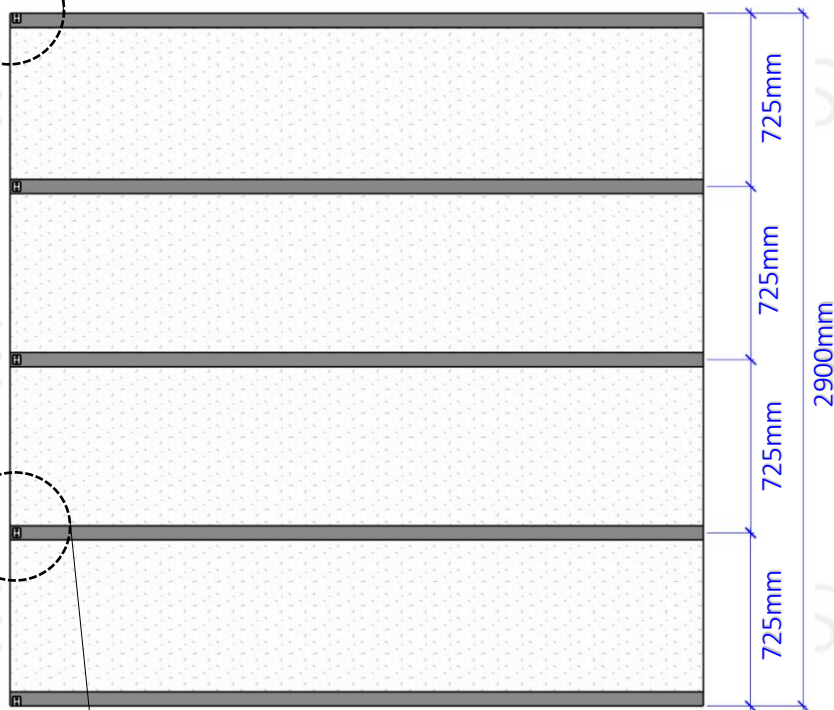

FRONT ELEVATION

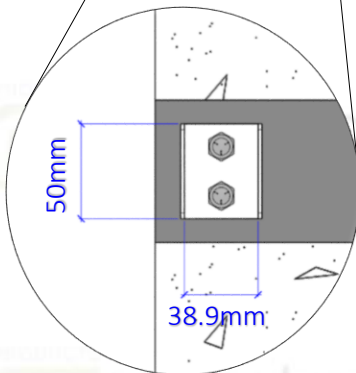

ELEVATION
Middle U-Bracket

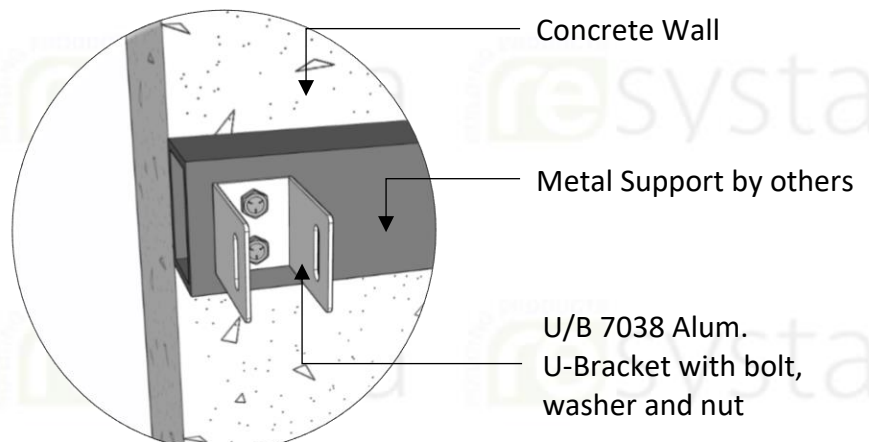

DETAIL 2
Middle U-Bracket

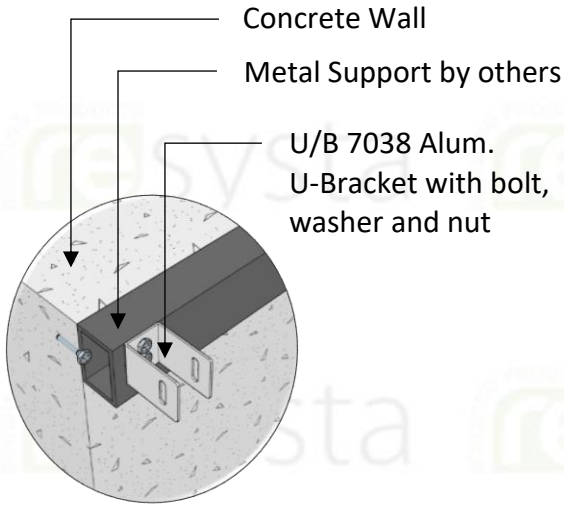

SECTION DETAIL 1
Upper End U-Bracket

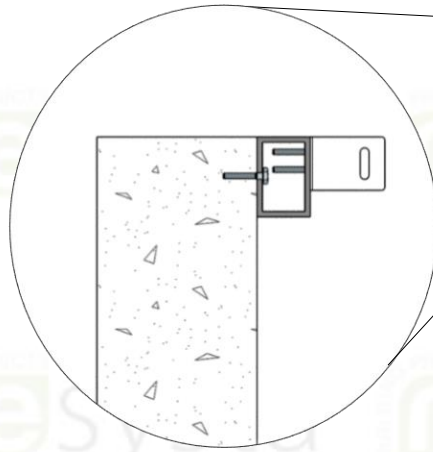

SECTION
Upper End U-Bracket

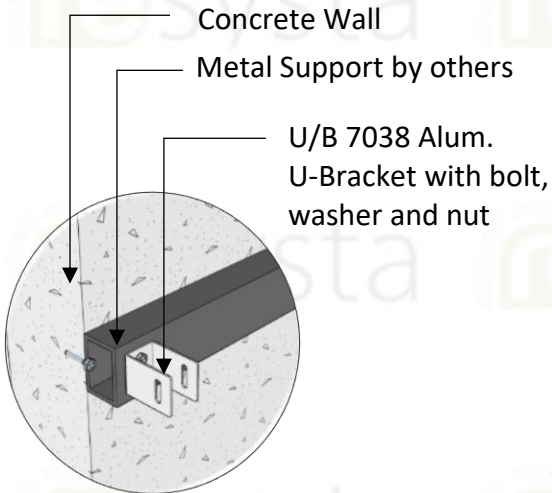

SECTION DETAIL 2
Middle U-Bracket

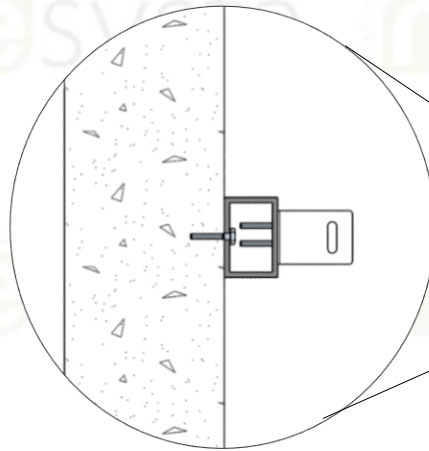

SECTION
Middle U-Bracket

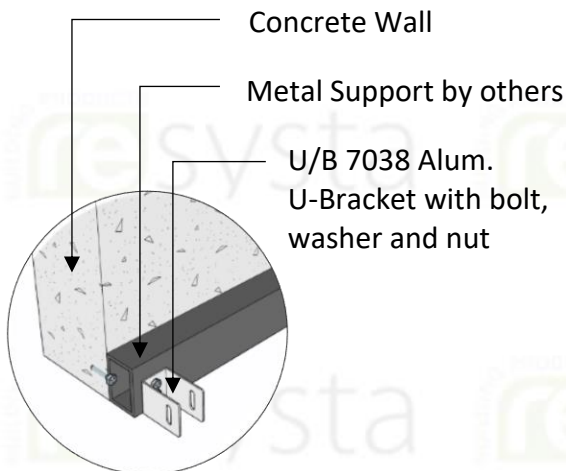

SECTION DETAIL 3
Lower End U-Bracket

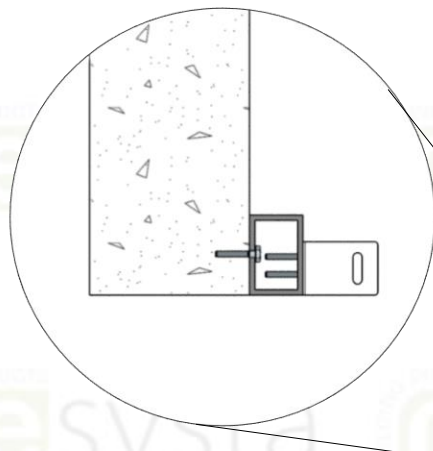

SECTION
Lower End U-Bracket

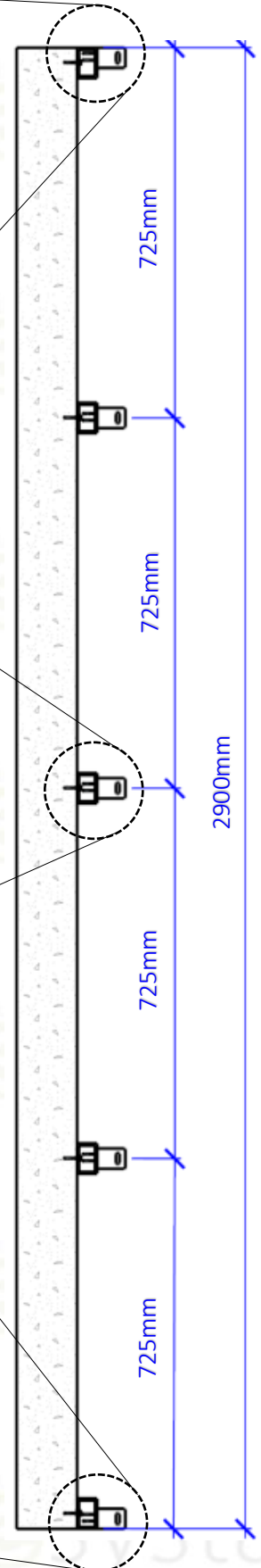

SECTION
Vertical Layout

- Slide the FPH 14038 N vertically into the U-bracket and install the bolt with a washer and nut to secure the Resysta Cladding profile.

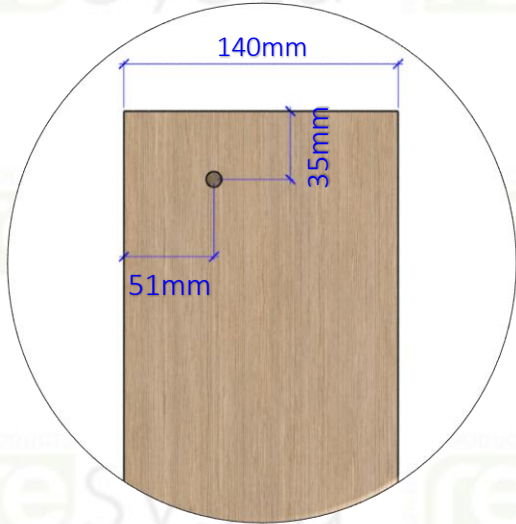

Hole location

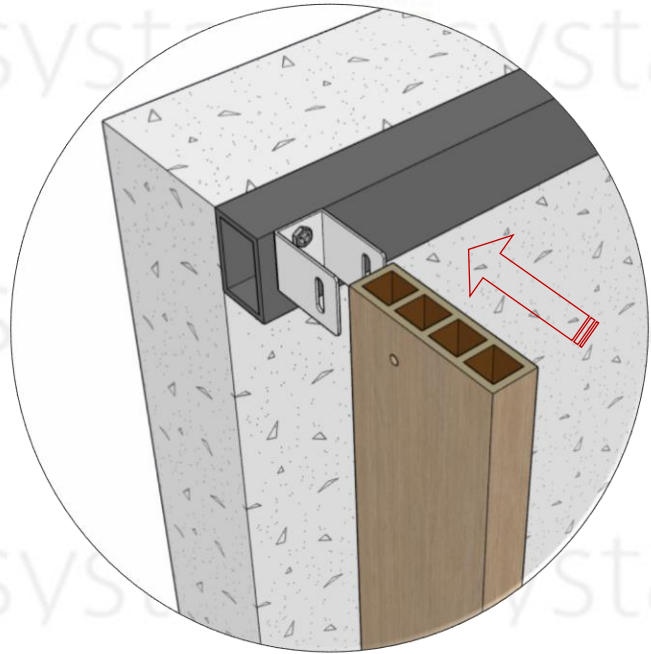

1-Drill and provide a 12.7mm diameter hole for the first location of bolt with washer and nut.

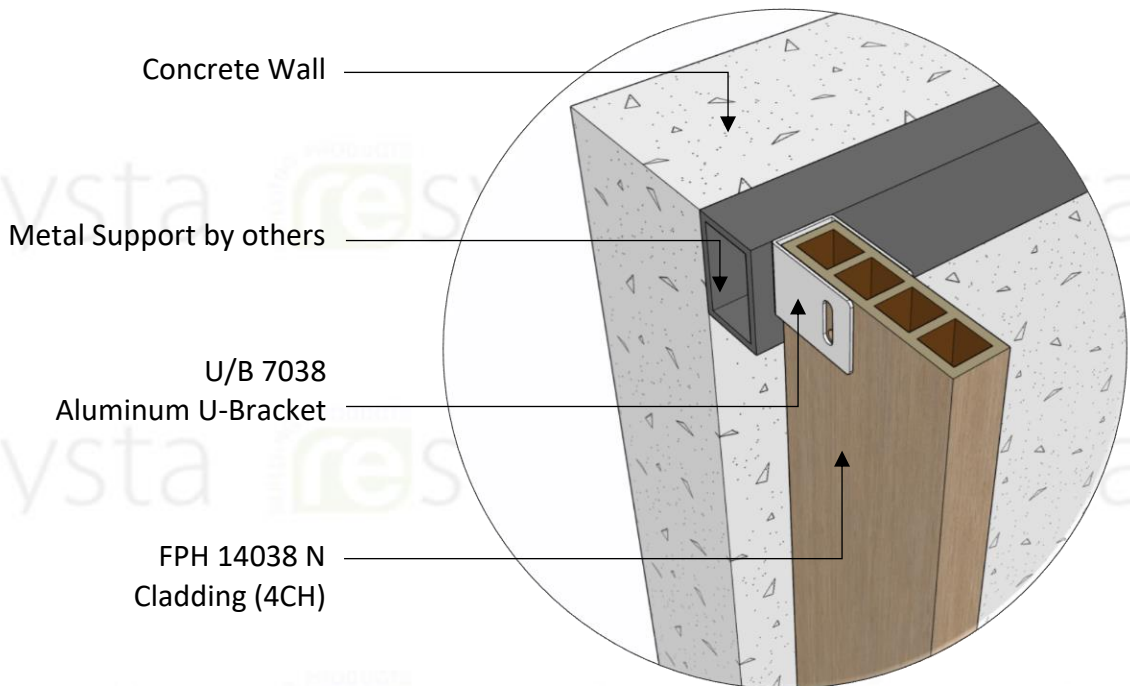

2-Slide the FPH 14038 N Resysta Cladding profile vertically into the U-bracket flashed and leveled on the metal support.

- Concrete Wall
- Metal Support by others
- U/B 7038 Aluminum U-Bracket with washer, bolt and nut
- FPH 14038 N Cladding (4CH)

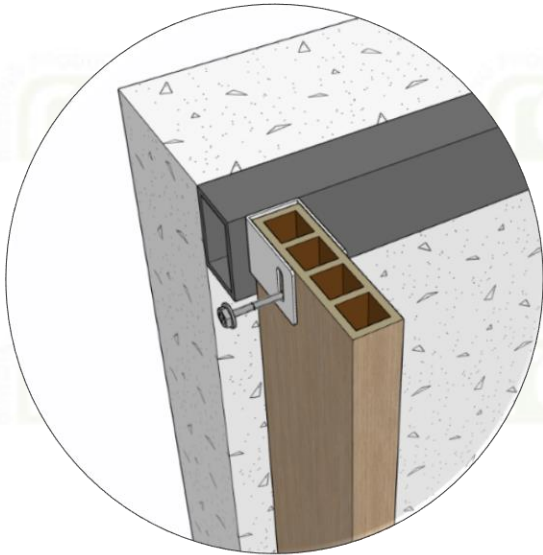

3-Install the bolt with washer and nut on the lower most part of the U-bracket hole.

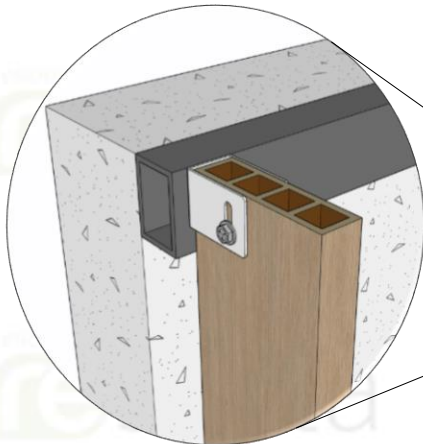
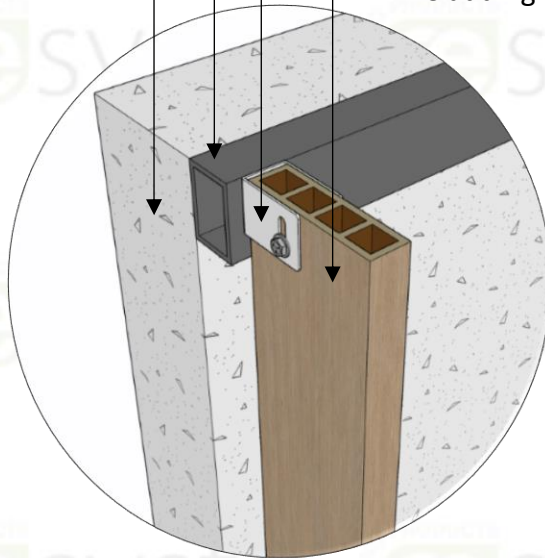

ISOMETRIC
Upper End Detail

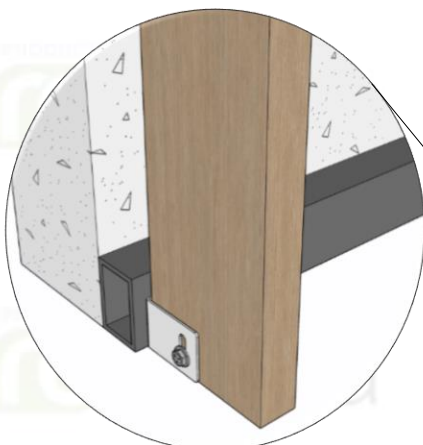

ISOMETRIC
Lower End Detail

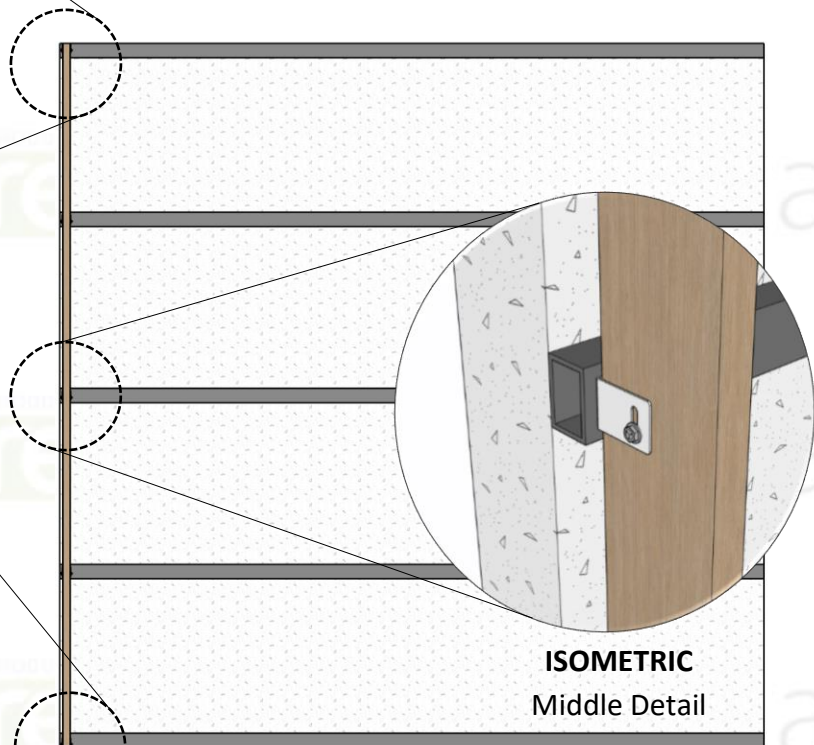

ISOMETRIC
Middle Detail

FRONT ELEVATION
Vertical Layout

Please note optional Hollow Cap Details

- If the profile is to be closed both ends.

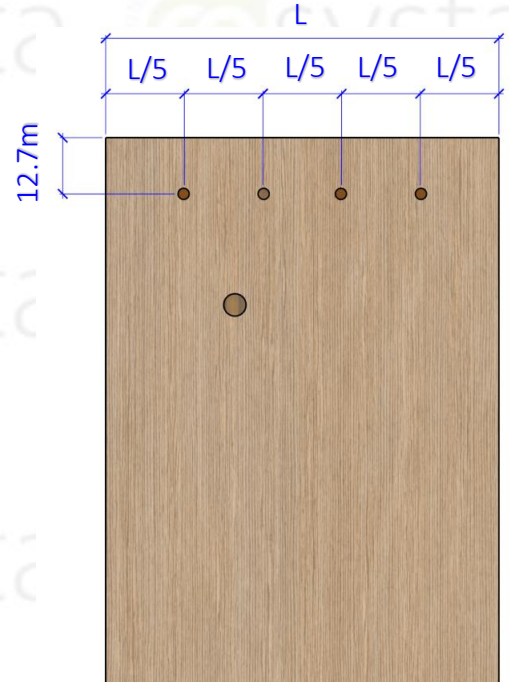

FRONT ELEVATION
Vertical Layout

1-On one side of the profile need to drill and provide 3.2mm diameter hole for every chamber for ventilation.

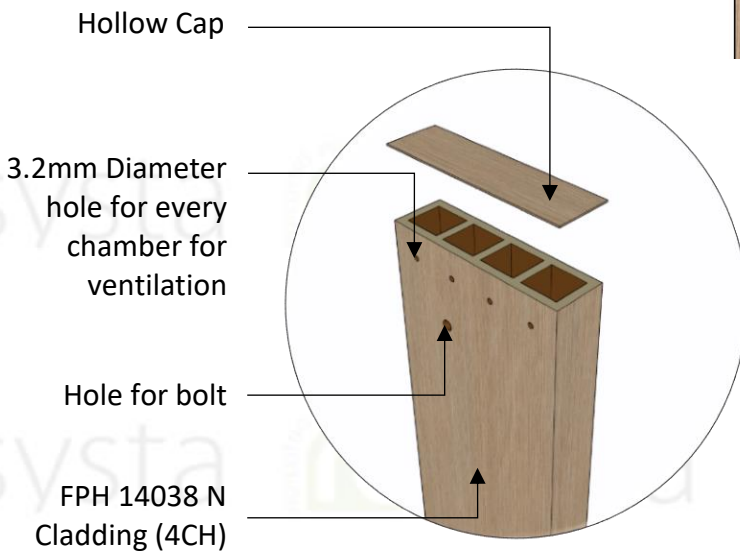

2-The End cap has a double-sided tape to stick on the profile.



ISOMETRIC
Upper Hollow Cap



ISOMETRIC
Lower Hollow Cap

6. Repeat steps 2.4 and 2.5, providing 100mm center to center space to each and every U-bracket and FPH 14038 N until reaching the end of the metal support.

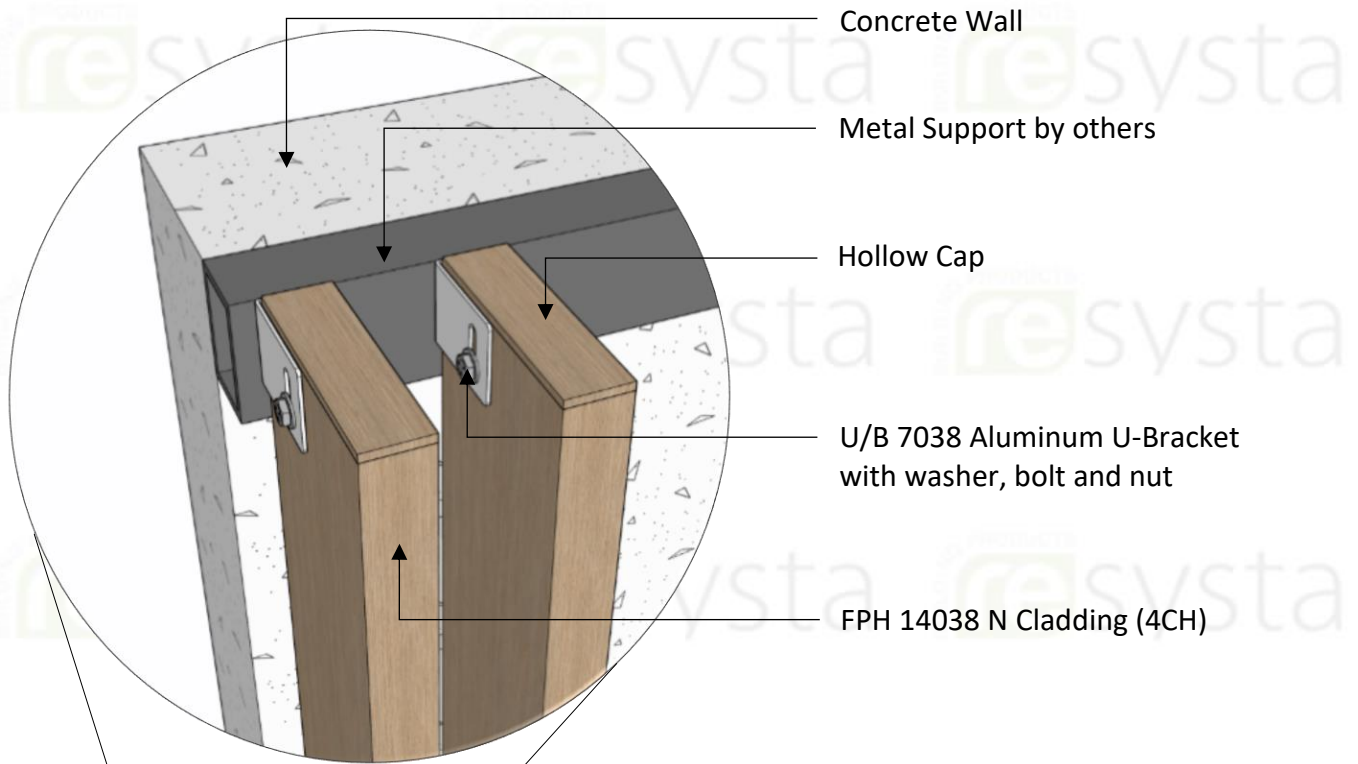

ISOMETRIC
Detail

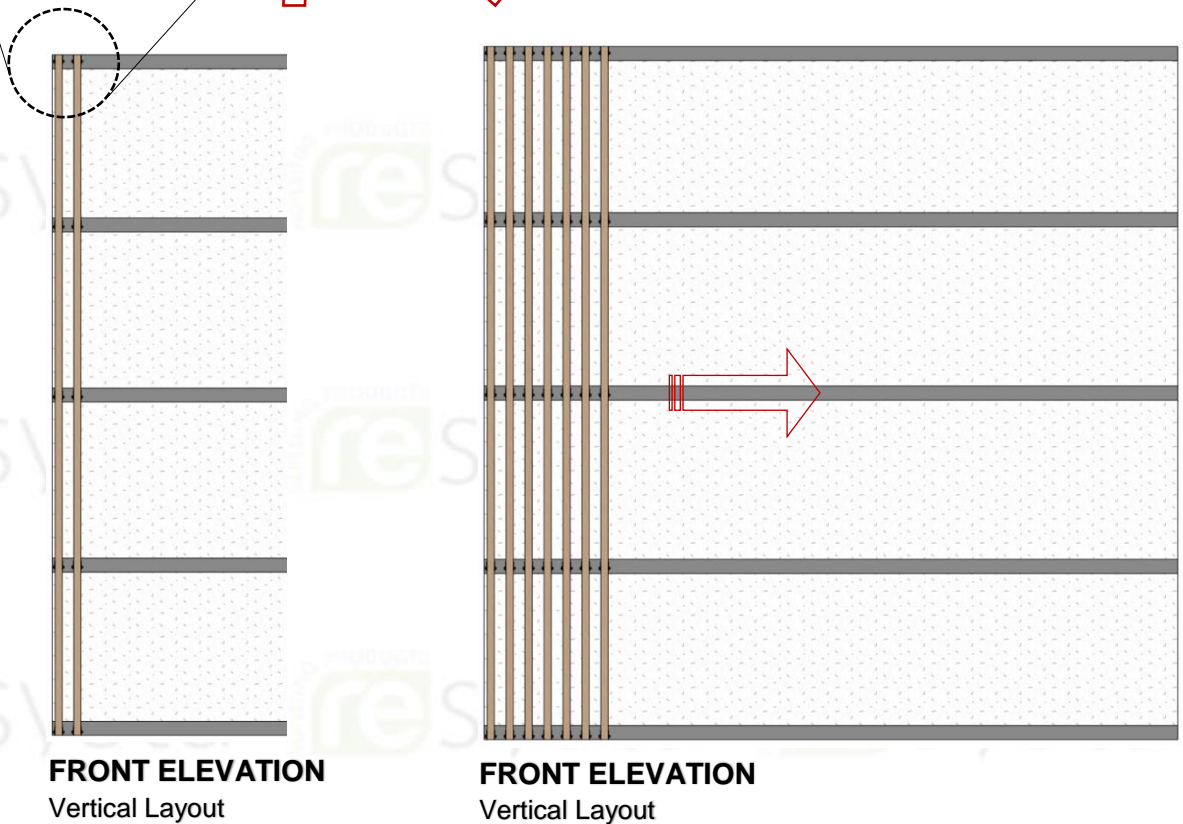

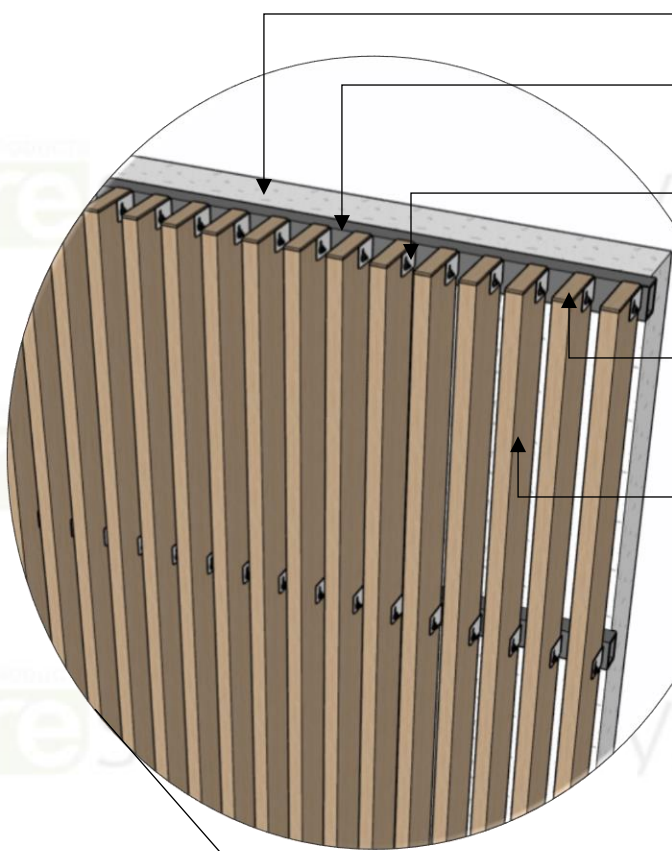

- Concrete Wall
- Metal Support by others
- U/B 7038 Aluminum U-Bracket with washer, bolt and nut
- Hollow Cap
- FPH 14038 N Cladding (4CH)

ISOMETRIC
Detail

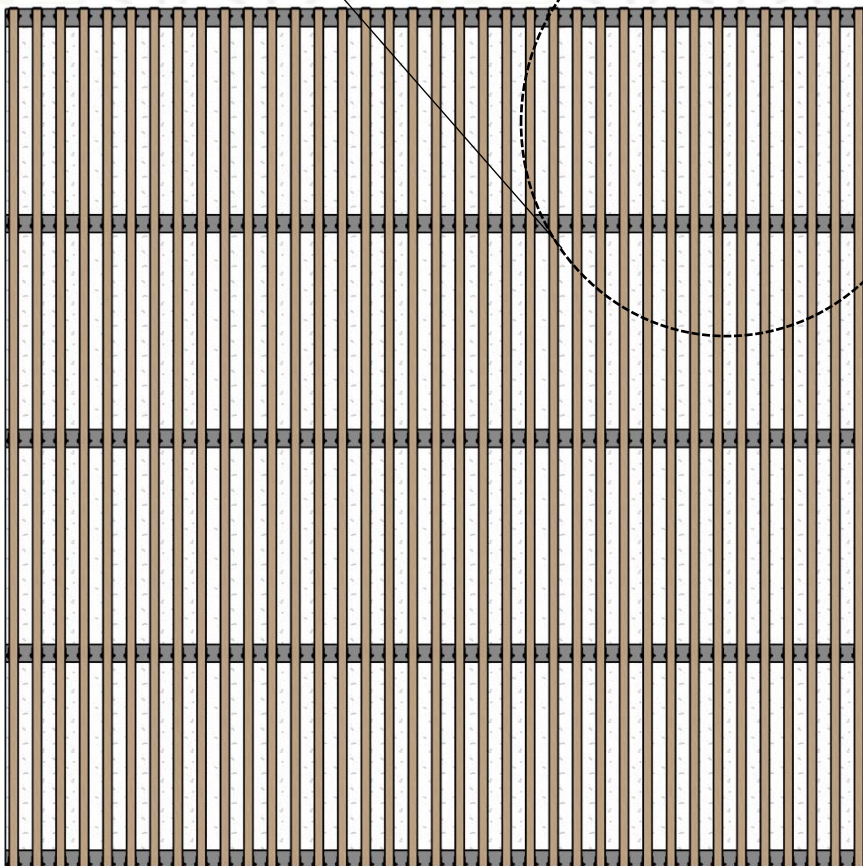

FRONT ELEVATION
Vertical Layout

SECTION 2.2 – Horizontal Layout

1. Check the layout and designed direction of the cladding to be installed; whether it is horizontal, vertical or depends on the design requirements.
2. Ensure that the metal support is 100% levelled and plumb before installing the aluminium U-bracket on the metal support.
3. The location of the metal support will vary depending on what type of Resysta Cladding is being used. Please refer the spacing of the metal support and U-Bracket on 1.4 U-Bracket Spacing.

PROCEDURES for FPH 14038 N Horizontal Layout

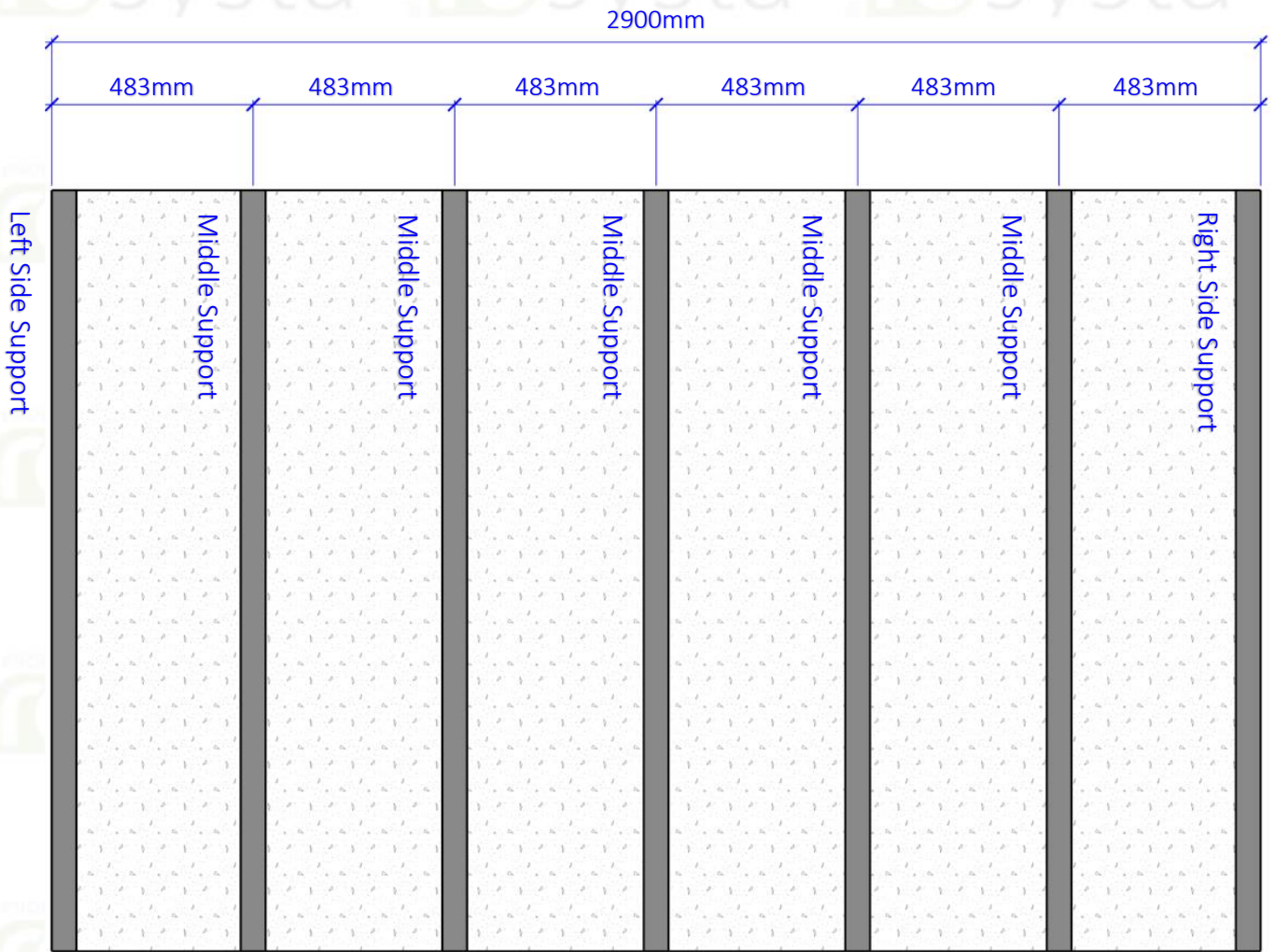

FRONT ELEVATION
Horizontal Layout

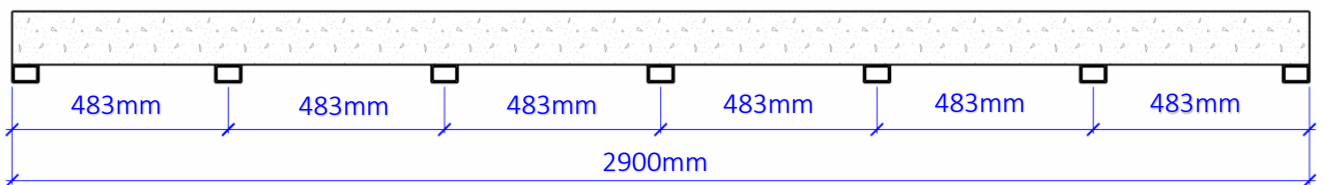

TOP VIEW
Horizontal Layout

4. Install the first U-bracket horizontally at the upper left side of the metal support flashed and plumb, followed by a U-bracket in every 483mm center of vertical metal support.

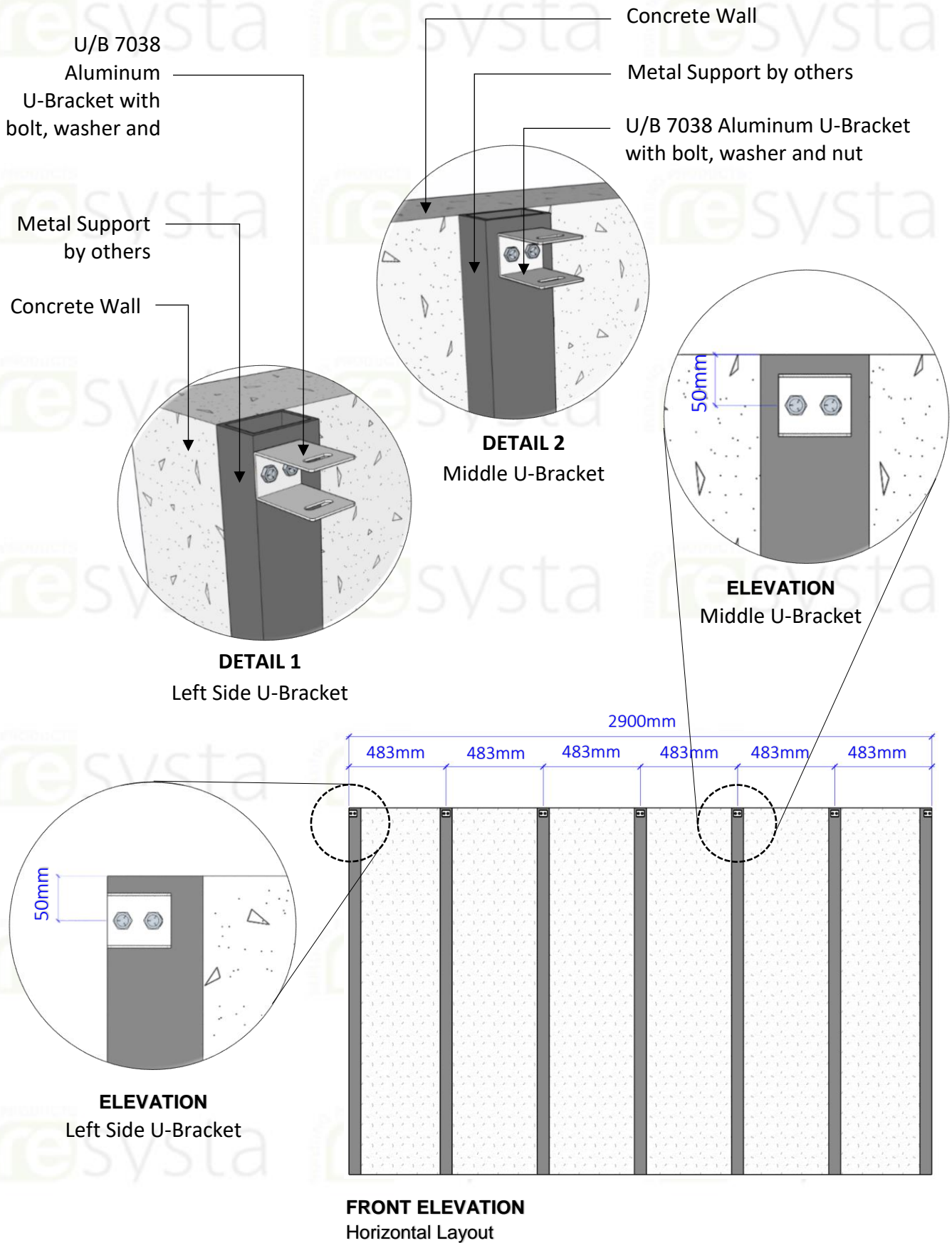

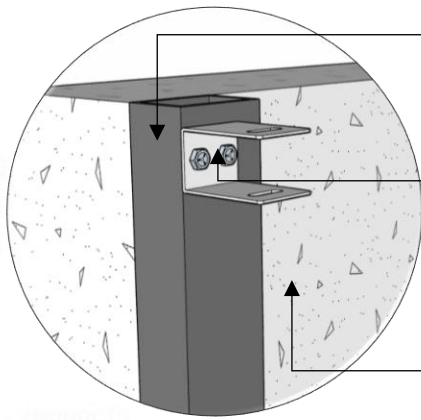

DETAIL 1
Left Side U-Bracket

Metal Support by others

U/B 7038 Alum.
U-Bracket with bolt,
washer and nut

Concrete Wall

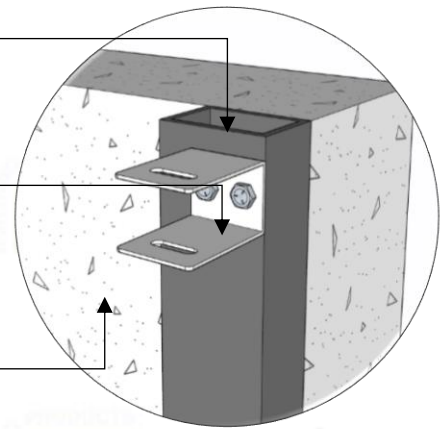

DETAIL 3
Right Side U-Bracket

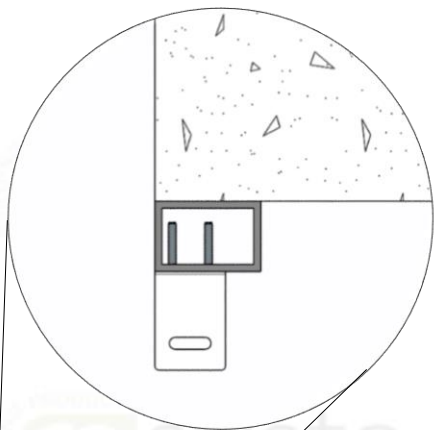

TOP VIEW
Left Side U-Bracket

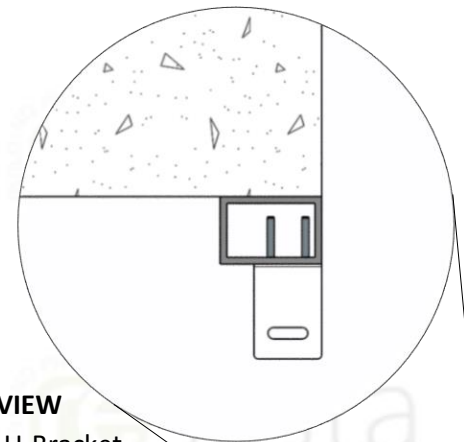

TOP VIEW
Right Side U-Bracket

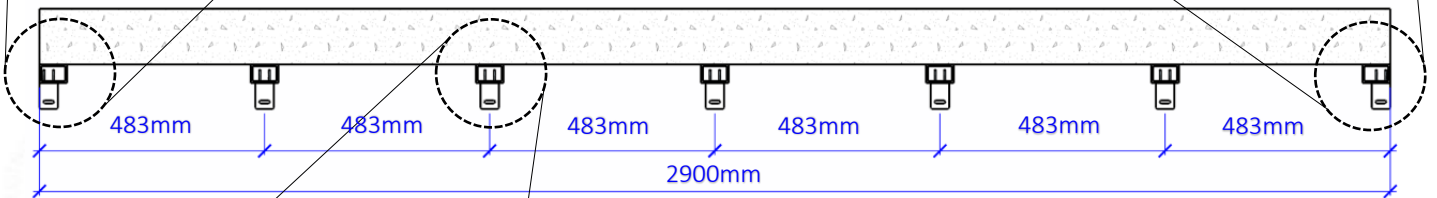

TOP VIEW
Horizontal Layout

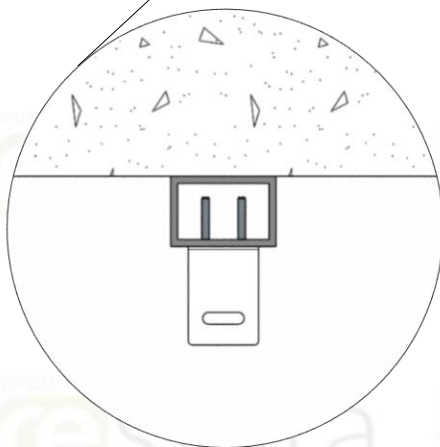

TOP VIEW
Middle U-Bracket

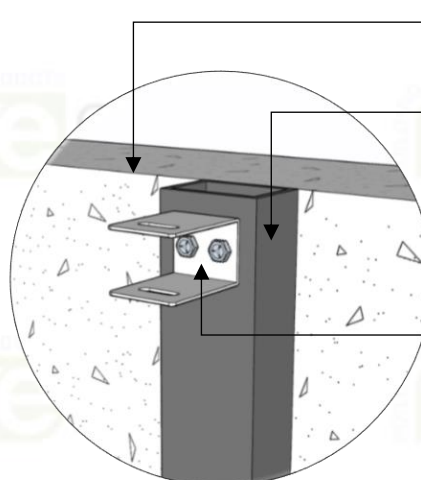

DETAIL 2
Middle U-Bracket

Concrete Wall

Metal Support by others

U/B 7038 Alum.
U-Bracket with bolt,
washer and nut

- Slide the FPH 14038 N horizontally into the U-bracket and install the bolt with washer and nut to secure the Resysta Cladding profile.

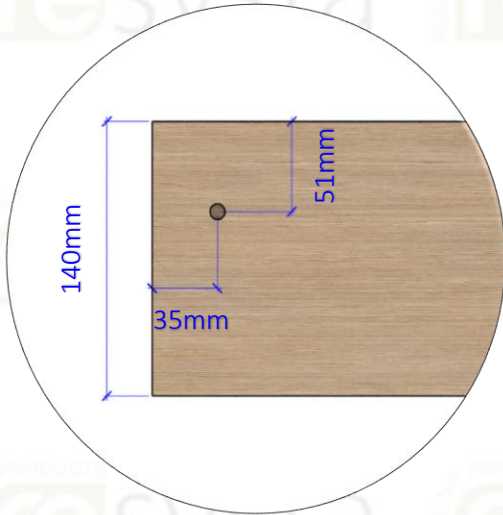

Hole location

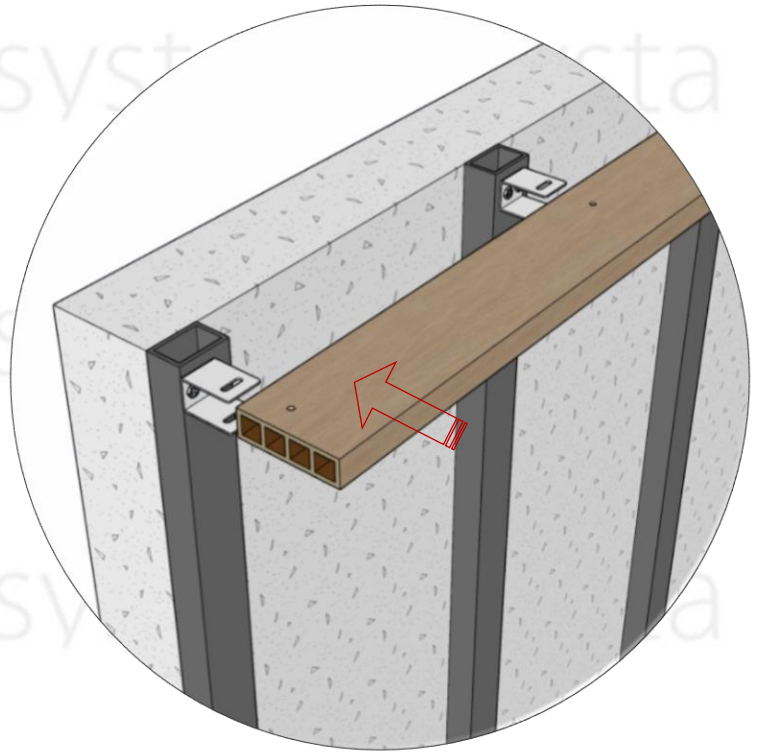

1-Drill and provide a 12.7mm diameter hole for the first location of bolt with washer and nut.

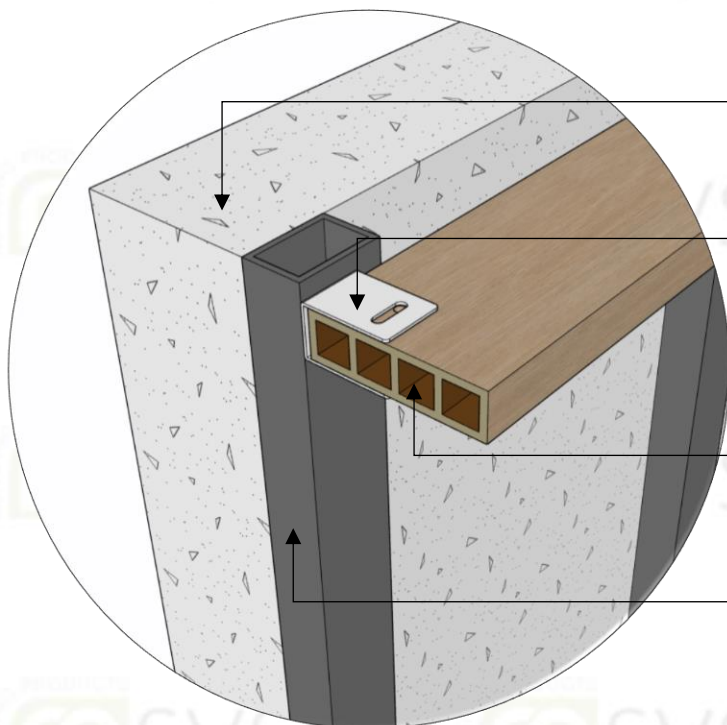

Concrete Wall

U/B 7038
Aluminum U-Bracket

FPH 14038 N
Cladding (4CH)

Metal Support by others

2-Slide the FPH 14038 N Resysta Cladding profile horizontally into the U-bracket flashed and plumb on the metal support.

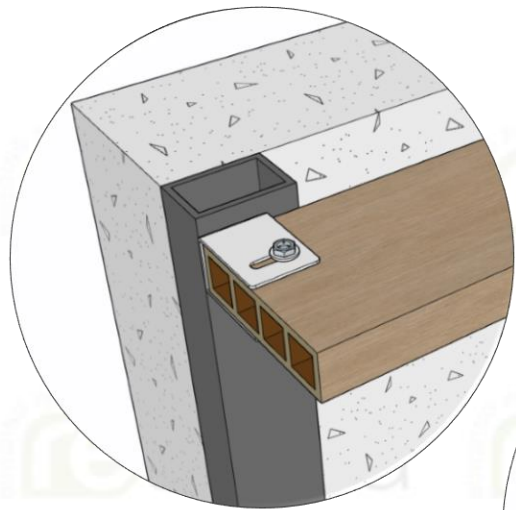

3-Install the bolt with washer and nut on the right side most part of the U-bracket hole.

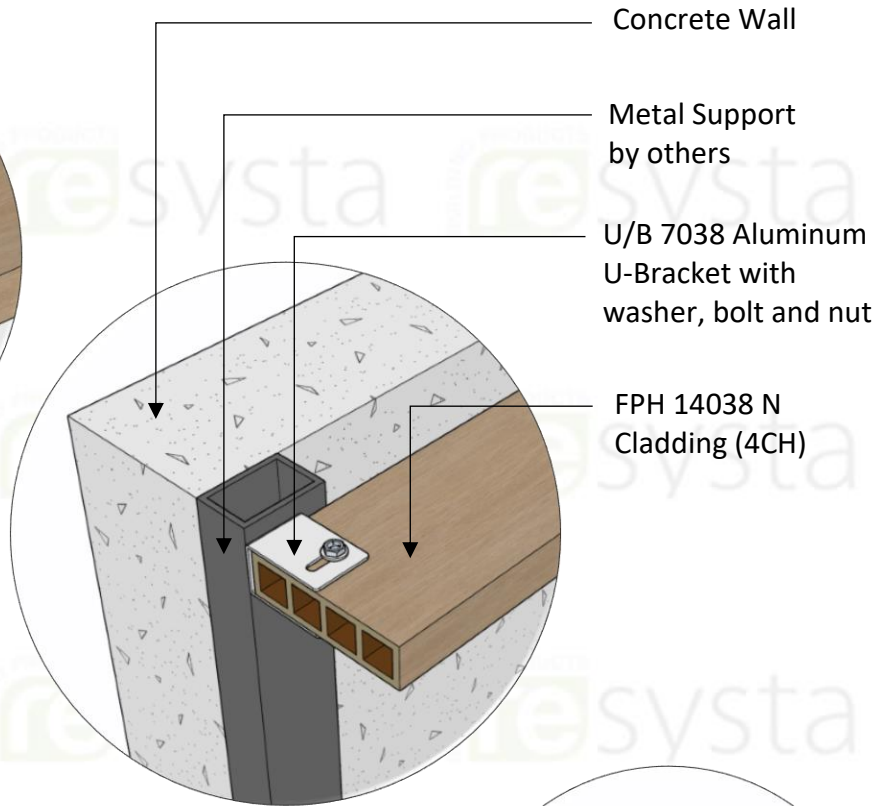

- Concrete Wall
- Metal Support by others
- U/B 7038 Aluminum U-Bracket with washer, bolt and nut
- FPH 14038 N Cladding (4CH)

ISOMETRIC
Detail

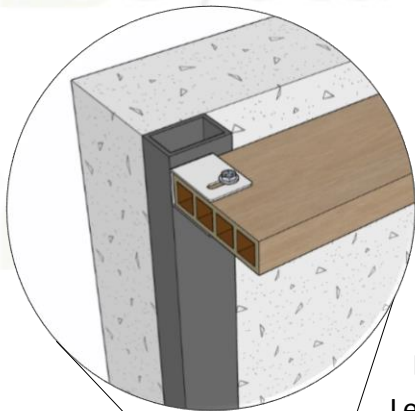

ISOMETRIC
Left Side Detail

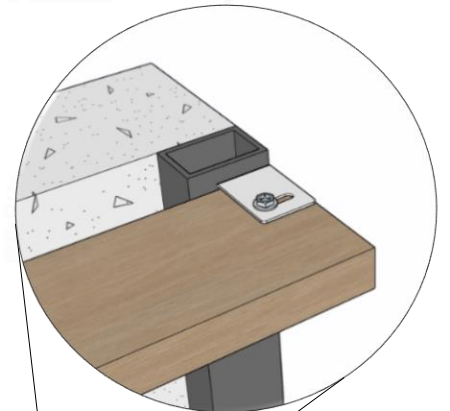

ISOMETRIC
Right Side Detail

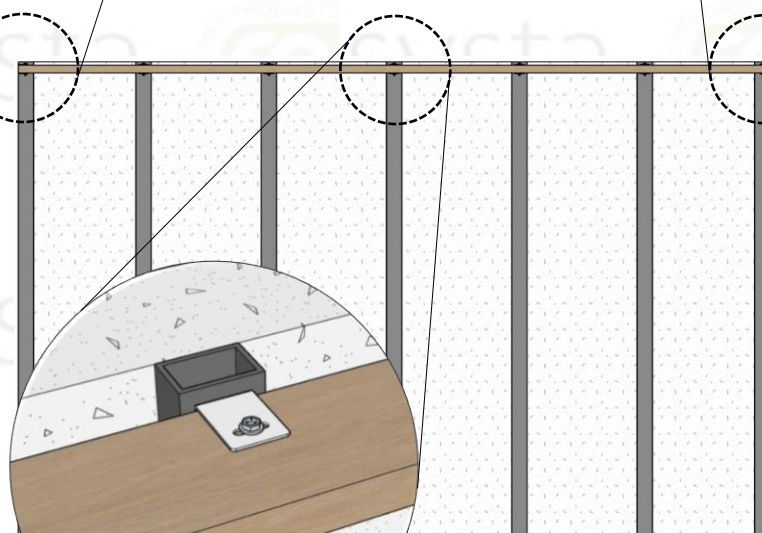

FRONT ELEVATION
Horizontal Layout

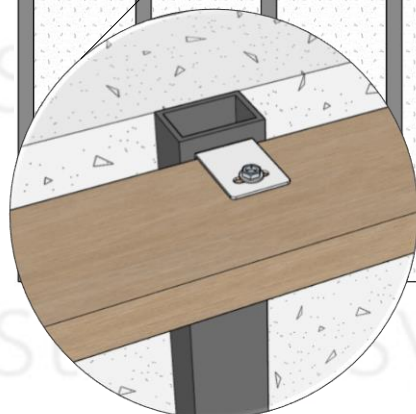

ISOMETRIC
Middle Detail

Please note optional Hollow Cap Details

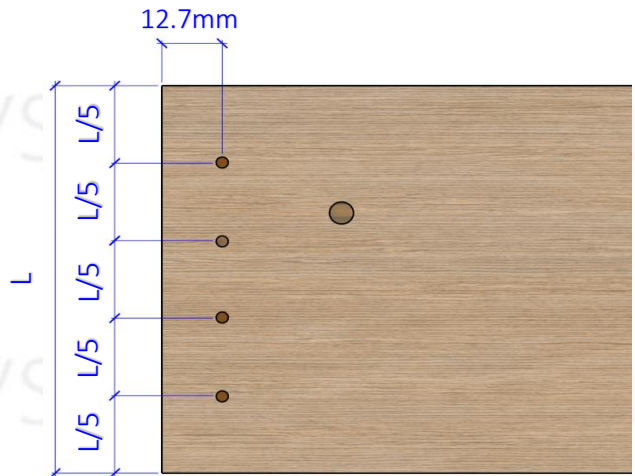

TOP VIEW
Horizontal Layout

1- If applying veneer caps to both ends of the FPH 14038 N you'll need to drill a 3.2 mm minimum diameter hole in every chamber to allow for ventilation. The location of the holes will depend on the Clients discretion based on the actual project conditions.

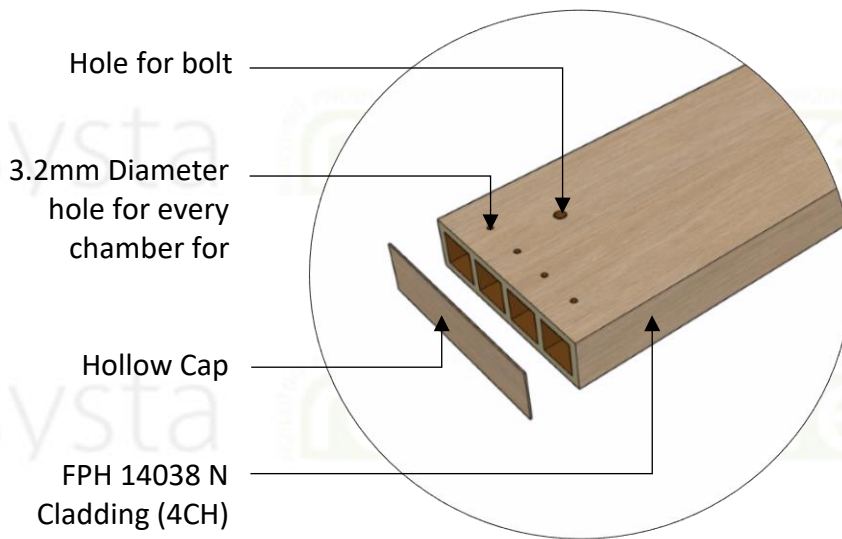

2-The hollow cap has a double-sided tape to stick on the profile.

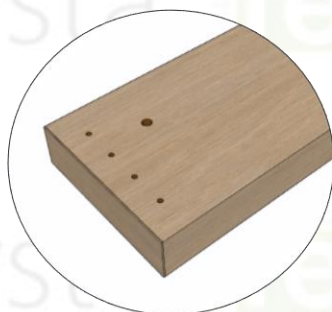

ISOMETRIC
Left Side Detail



ISOMETRIC
Right Side Detail

- Repeat steps 2.4 and 2.5, providing enough space to each and every U-bracket and FPH 14038 N until reaching the end of the metal support.

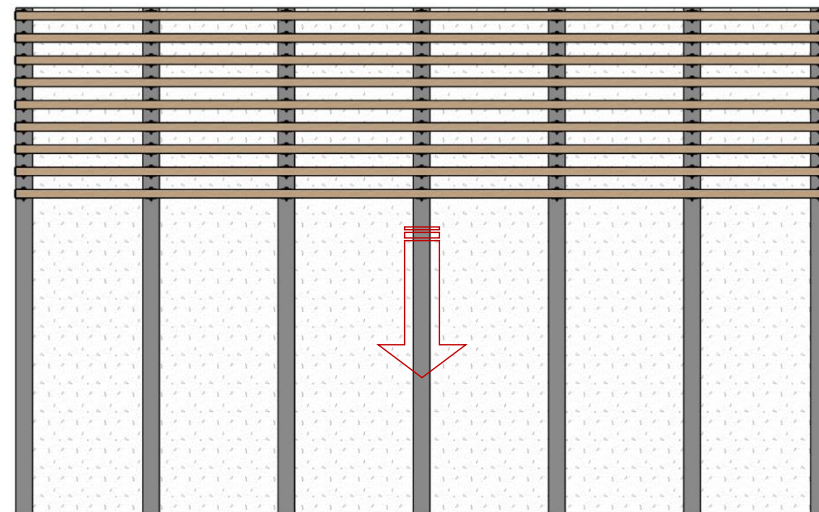
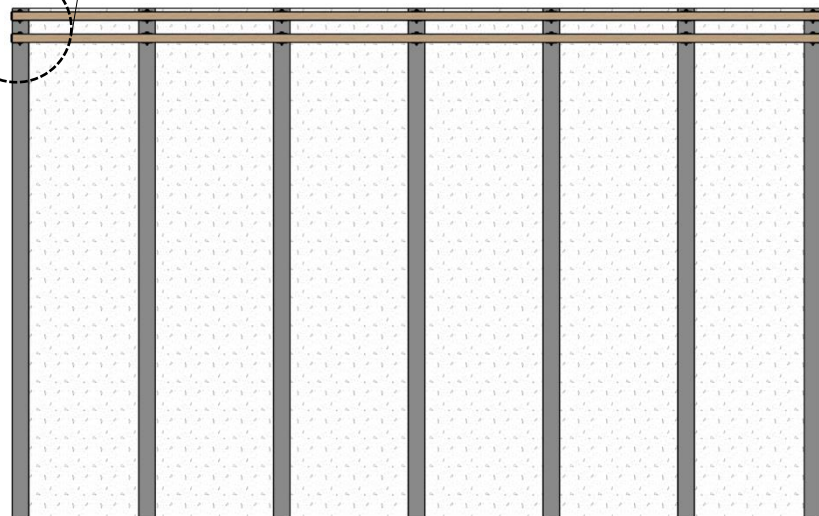
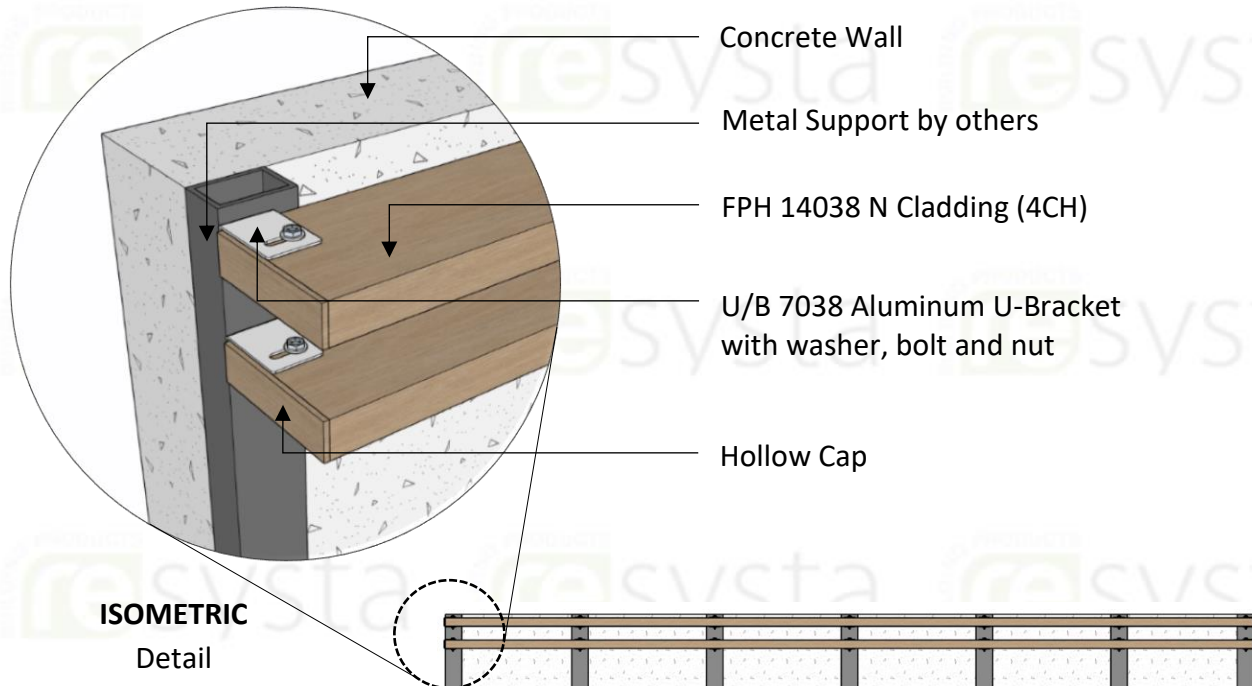

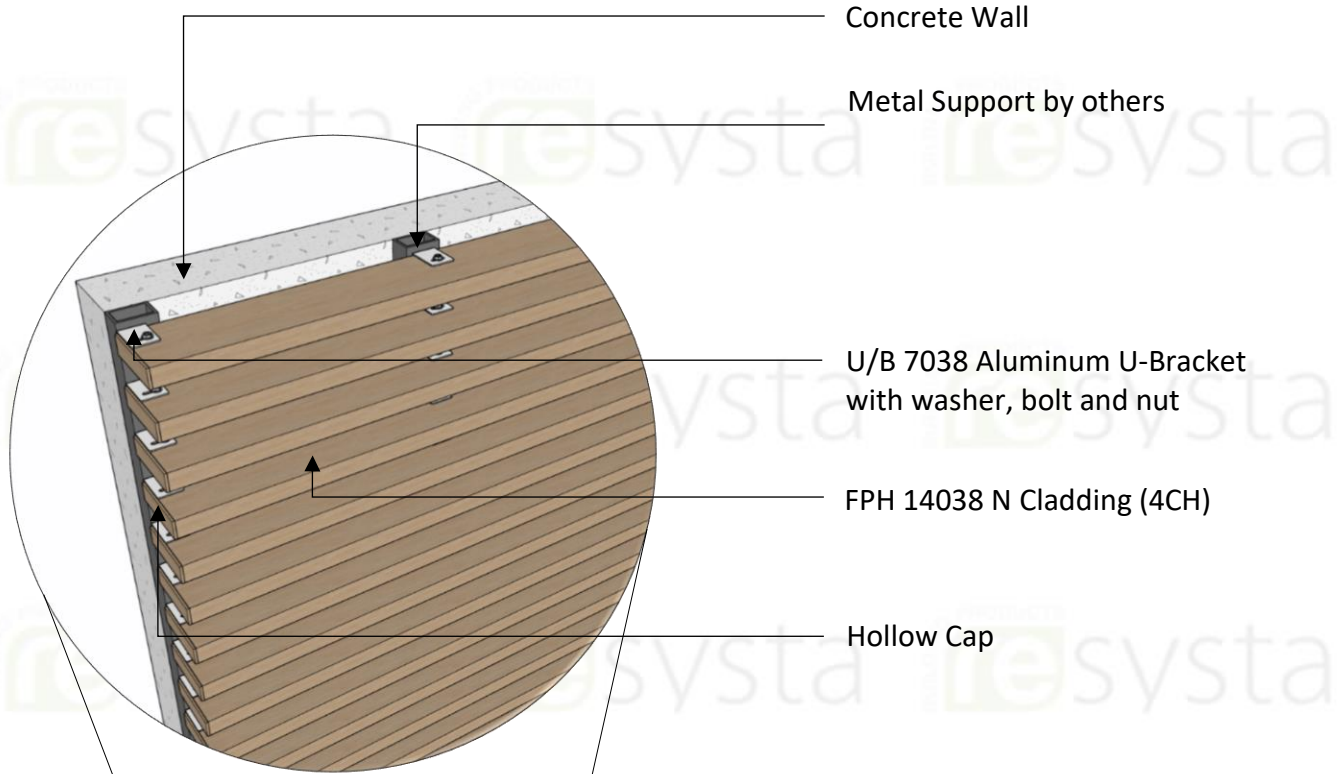

ISOMETRIC
Detail

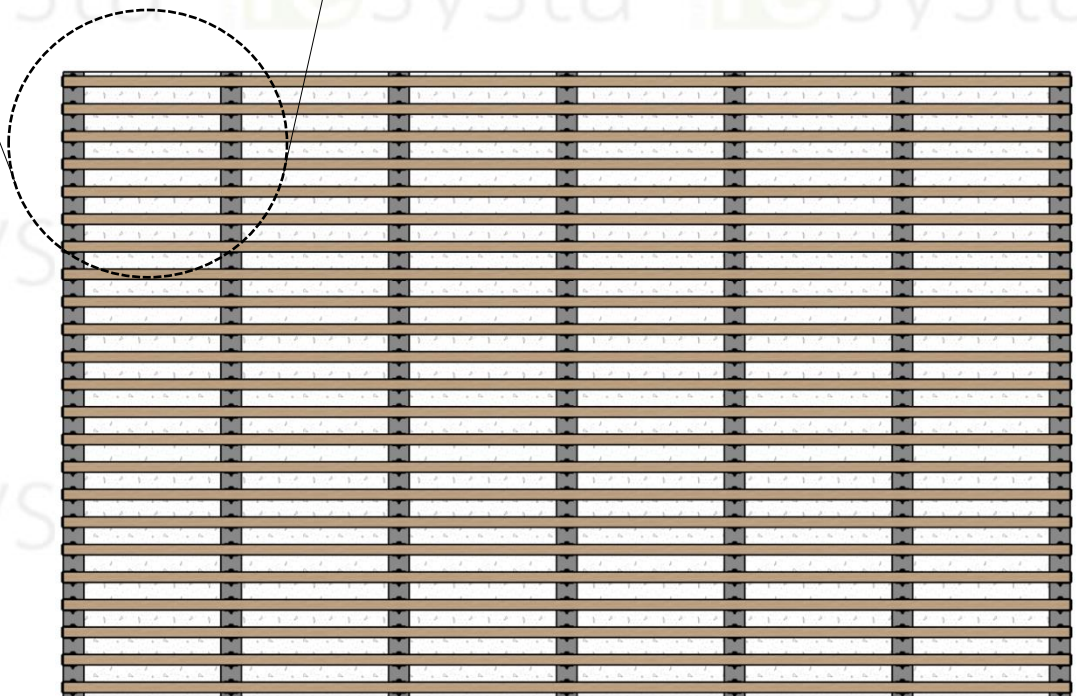

FRONT ELEVATION
Horizontal Layout

3. General Advice

SECTION 3.1 – Expansion Joint

Expansion joint caters for temperature- dependent linear expansion of 1mm gap per board every 10 degrees in temperature change between the ends of the planks. e.g. 2.90m plank= approx. 3mm distance. If the planks are installed closed to a wall the distance here should be 10mm. (Refer to expansion chart)

Table 1.1

Resysta Wall Cladding Board Gap Guide				
	Trim Gap of Wall Cladding Boards			
Temperature at Installation	Below 0 °C	15 °C	20 °C	30 °C
Amount for Wall Cladding Profile	10mm	7mm	3mm	0mm
-Length of 2900mm				

- 3.1.1 The Dimensional change of Resysta is solely dependent on the thermal expansion. Air, humidity and water have no influence on dimensional change. Thermal expansion must be considered at installation.
- 3.1.2 Cutting to length should be carried out at consistent material temperature. Therefore, the materials should be stored in the shade or in areas where it is not exposed to direct sunlight. The material can warm up considerably in the sun, leading to an increased change in length. In the case of more distinct fluctuations in material temperature, cutting to length may have to be adapted accordingly.
- 3.1.3 Resysta has a high vapor diffusion resistance. Please consider at installation.
- 3.1.4 Resysta has a class A fire rating (ASTM-E84).
- 3.1.5 Cut-off pieces and/or abrasive dust have to be disposed separately. Please comply with regulations of your competent waste management. You may under no circumstances burn Resysta yourself.

SECTION 3.2 – Expansion Joint

- 3.1.6 Resysta building products is not responsible for information shown on all details beyond specification scope of work BID/quoted and as indicated contract documents.
- 3.1.7 Details of adjustment work are shown for completeness only. The project Architect / Project Engineer / Erecting Contractor supplying and/or installing the structural support is responsible for its design/installation to accommodate all loads imposed upon the products.
- 3.1.8 Our Engineer is limited to the load carrying components of the siding system and its fasteners shown on the subsequent drawings. The components are supplied by other parties.
- 3.1.9 These drawings are the copyright property of Resysta Building Products, Inc.
- 3.1.10 Please read our installation and design recommendation documents for further information that may be important for your specific project or installation.
- 3.1.11 Ensure a steady material temperature when cutting the boards to size. The cutting has to be done under constant conditions. e.g., inside or in shade.
- 3.1.12 Always consider the linear expansion of Resysta, which is dependent on the temperature but not air humidity. See Table 1.1 for more information.
- 3.1.13 Only use construction fastening material and hardware suitable for outdoor use (e.g., Stainless Steel Screws).

SECTION 3.3 – Disclaimer

Resysta Deco Cladding has been specially developed for their named application and are not a structural material. The items have no general technical approval and are therefore not suitable for supportive construction purposes. Local building codes as well as installations and technical information should be considered. Resysta products should be stored on a flat and level surface. If planks are stored on stickers/slats ensure that there is a distance of no more 2900mm between them. The Resysta cladding must be installed by an authorized professional installer.

For more details, please visit our web site <https://www.resysta-asia.com>