

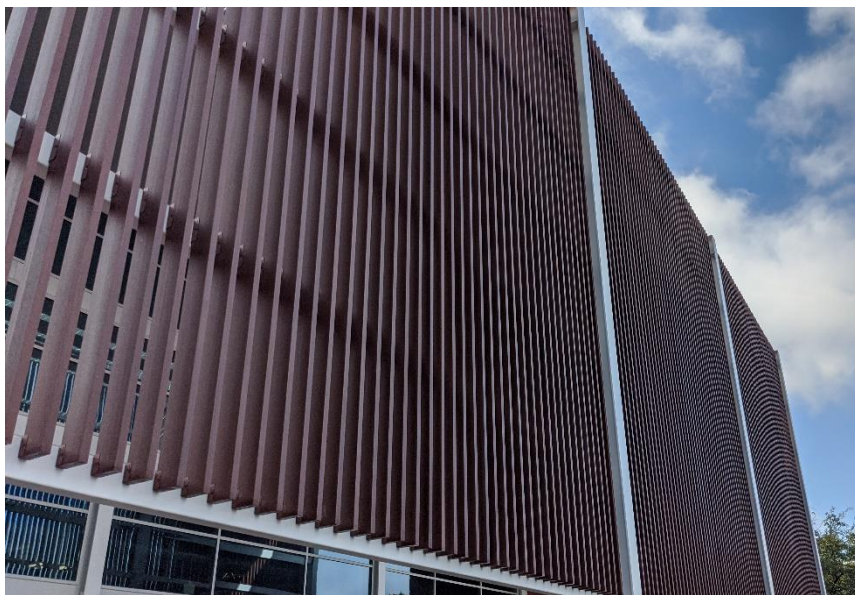

# INSTALLATION GUIDE

## RESYSTA U-BRACKET



### 1. Introduction

1.1 Material Components

1.2 Basics

1.3 Scope of Profiles

### 2. Installation Guide

### 3. General Guidelines

3.1 Expansion Joint

3.2 General Note

3.3 Disclaimer

## 1. Introduction

Resysta is an extremely durable, timber look-alike, building material. It is resistant to damage from the sun, rain, snow and even salt water. Unlike wood, it requires minimal maintenance and is highly resistant to pests, mold and cracks. Unlike other composite materials, it closely resembles the look and feel of natural wood, with a smooth surface finish. Resysta meets most of the future environmentally sustainable material requirements concerning recycled and fully recyclable materials. Resysta is used for its architectural aesthetic, and not for structural support.

### 1.1 Material Components

A combination of these three basic raw materials make up the simple components that create Resysta. This innovative material offers designers and architects new creative horizons to utilize its compelling and unique appearance.



Approx. 60% RICE HUSK + Approx. 22% COMMON SALT + Approx. 18% MINERAL OIL

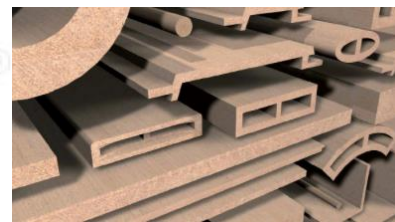

= RESYSTA PRODUCT





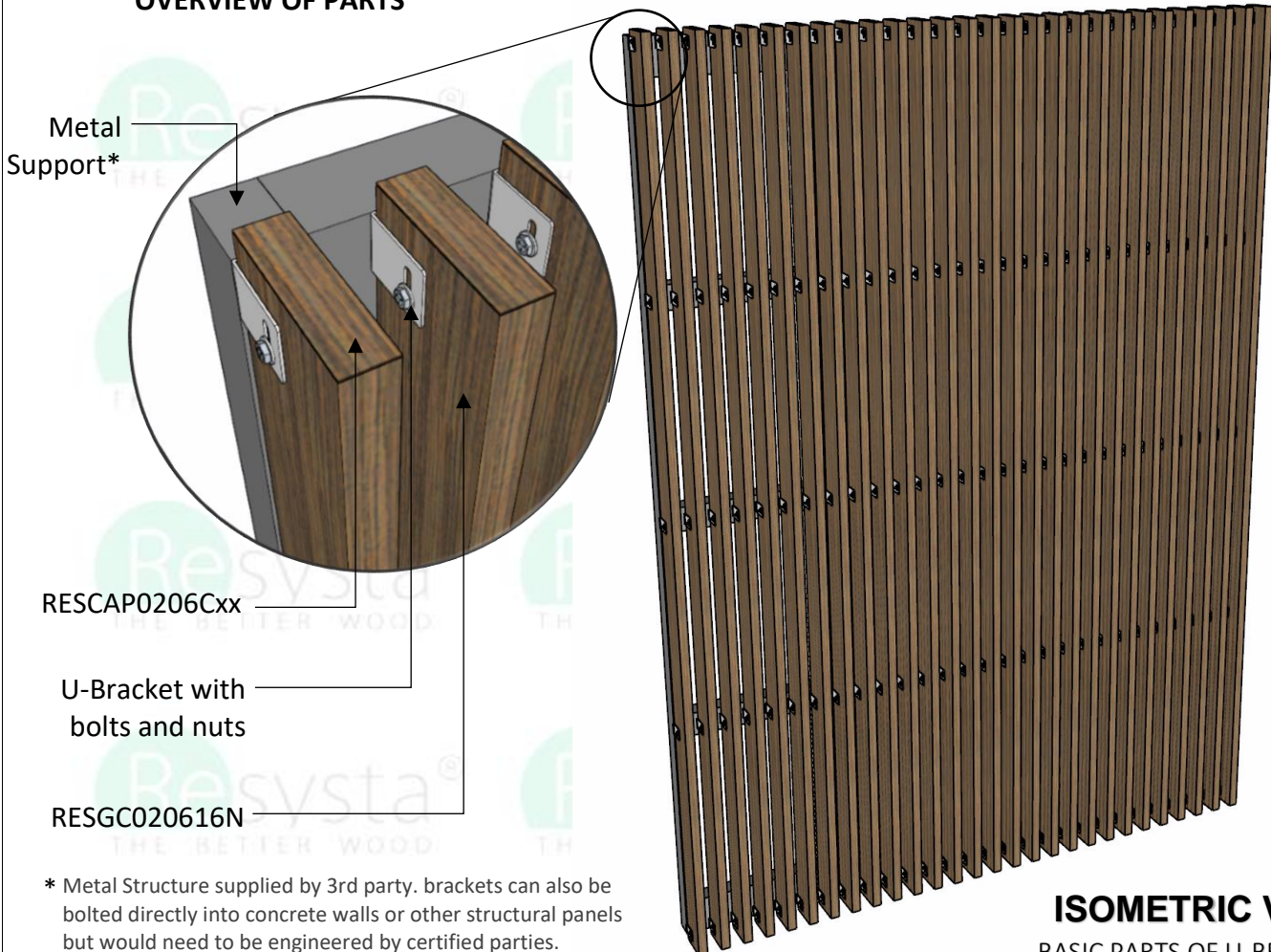



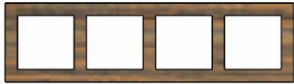

### 1.2 Basics

#### OVERVIEW OF PARTS

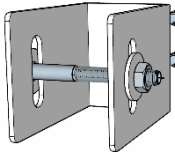

\* Metal Structure supplied by 3rd party. brackets can also be bolted directly into concrete walls or other structural panels but would need to be engineered by certified parties.

**1.3 Scope of Profiles**

NO.	PRODUCT NAME AND SPECIFICATION	ISOMETRIC VIEW	FRONT VIEW
1	<b>RESGC020616N</b> 1½" x 5½" x 16' Hollow Rectangular Profile		
2	<b>RESGC11223412</b> 1½" x 2¾" x 12' Hollow Rectangular Profile		
3	<b>RESGC1020612N</b> 1½" x 5½" x 12' Hollow Rectangular Profile with Metal Insert		
4	<b>RESGC11223412</b> 1½" x 2¾" x 12' Hollow Rectangular Profile with Metal Insert		
5	<b>RESCAP0206Cxx</b>		
6	<b>RESUB112234</b> 1½" x 2¾" Aluminium U-bracket with bolt, washer and nut		

NOTE: Table above shows products commonly used for wall cladding. To view a complete list of products, please refer to our Resysta brochure or visit our web site <http://www.resystausa.com>

## 2. Installation Guide

### A. PROCEDURES for RESGC020616N and RESGC11223412 :

- 2.1 Check the layout and designed direction of the cladding to be installed; whether it is horizontal, vertical or depends on the design requirements.
- 2.2 Ensure that the metal support is 100% levelled and plumb before installing the aluminium U-bracket on the metal support.
- 2.3 Establish the gridline of the metal support with a maximum 36" center to center of each horizontal support before installing the U-bracket.

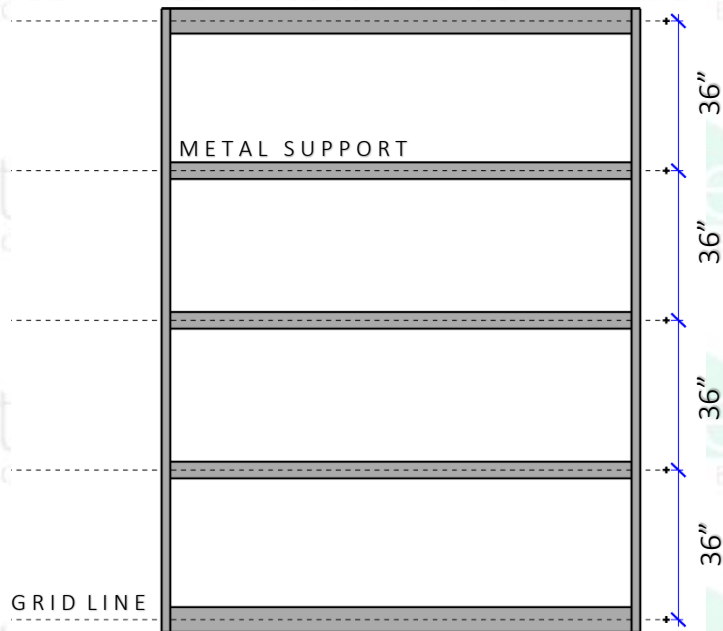

- 2.4 Install the first U-bracket at the corner end of vertical metal support followed by a U-bracket in every 36" center of horizontal metal support.

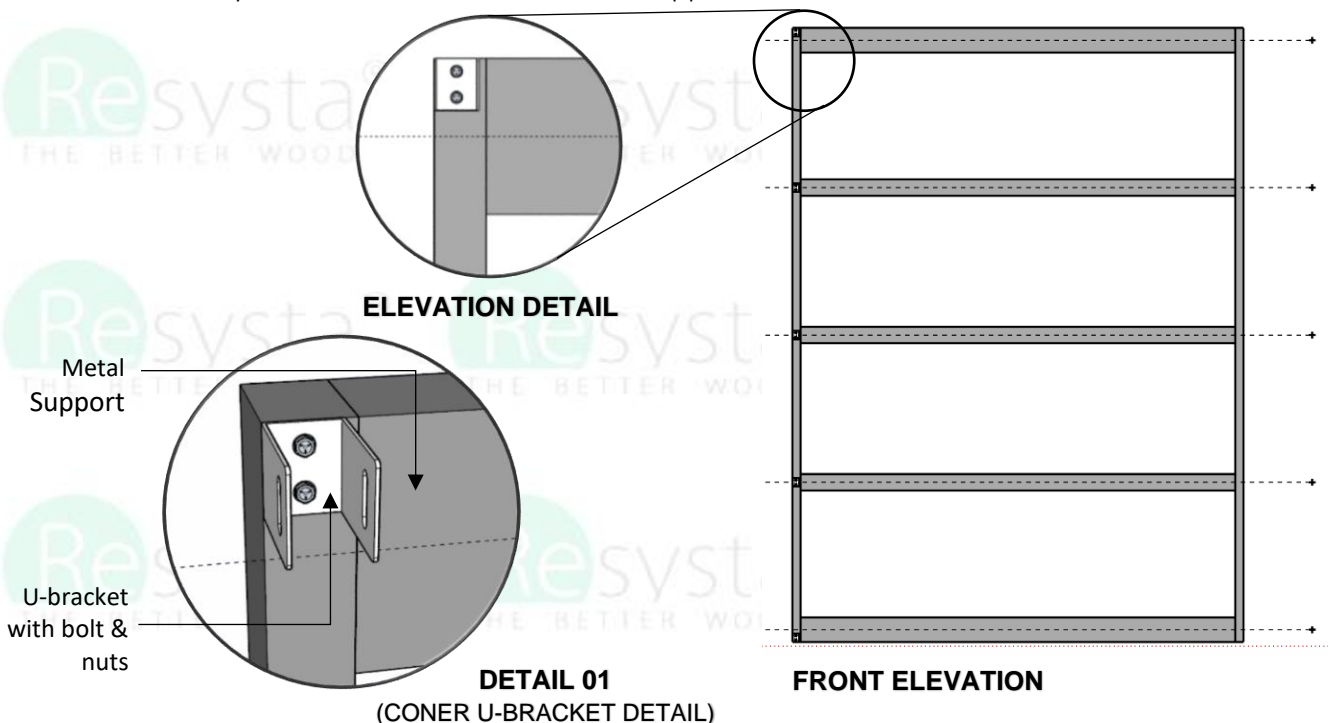

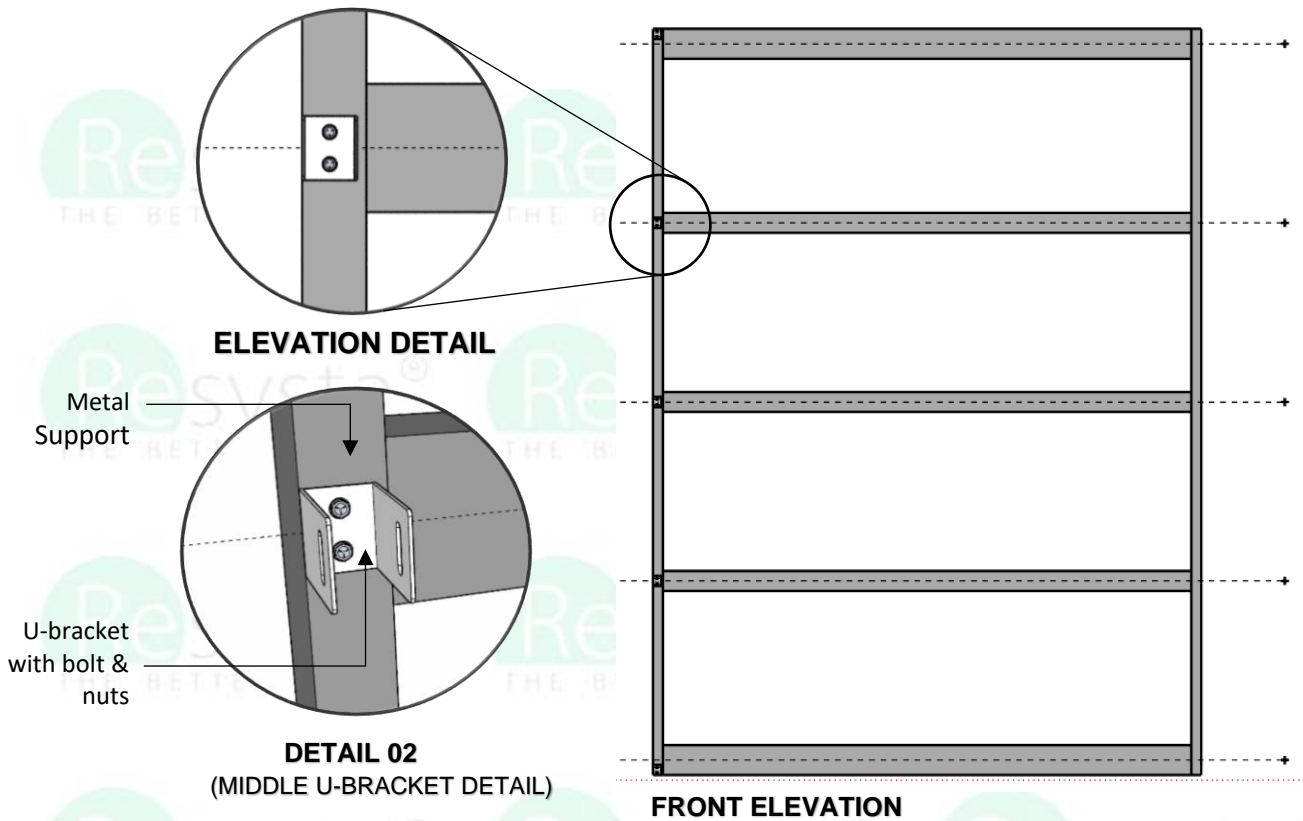

2.5 Slide the RESGC020616N into the U-bracket and install the bolt with washer and nut to secure the Resysta profile. Provide an overhang of 1" on top and bottom of the RESGC020616N profile.

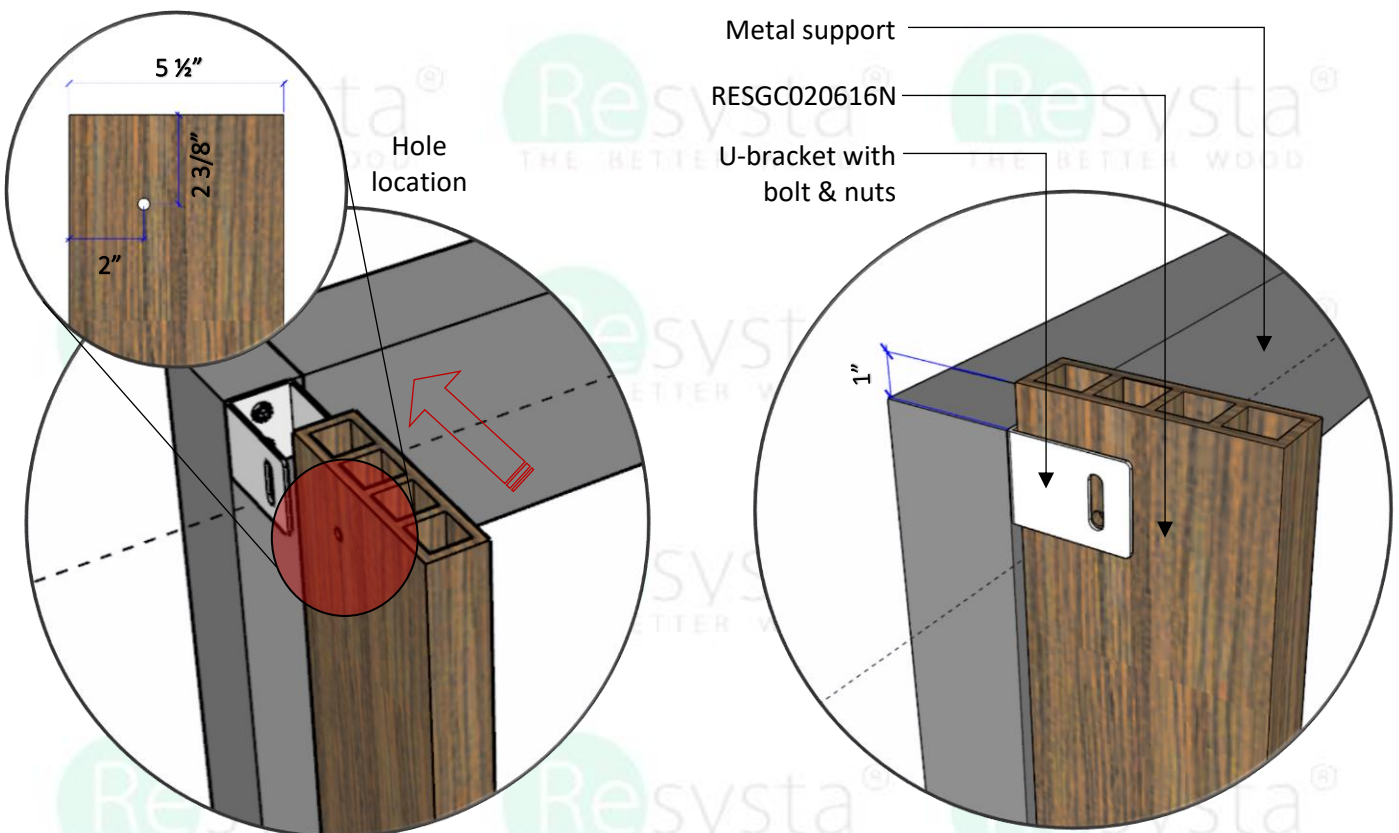

1-Drill and provide a 1/2" diameter hole for the first location of bolt with washer and nut.

2-Slide the RESGC020616N Resysta profile into the U-bracket with an overhang clearance of 1" on top of the RESGC020616N profile.

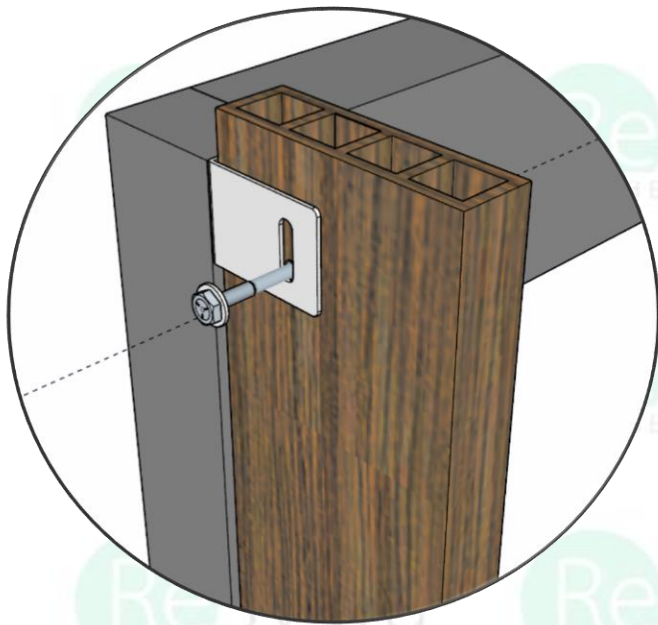

3-Install the bolt with washer and nut on the lower most part of the U-bracket hole.

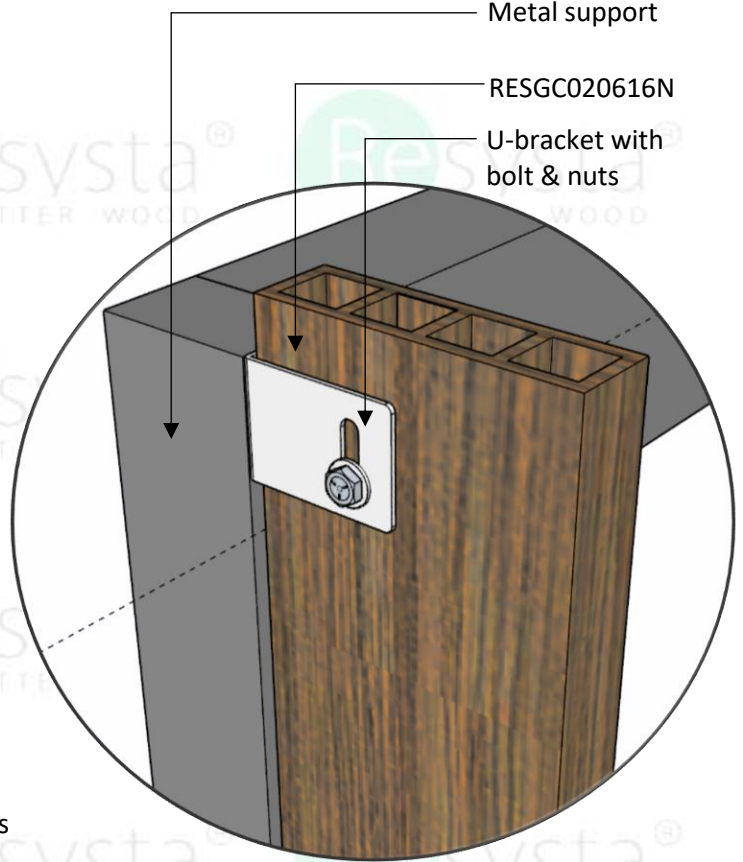

Metal support  
RESGC020616N  
U-bracket with bolt & nuts

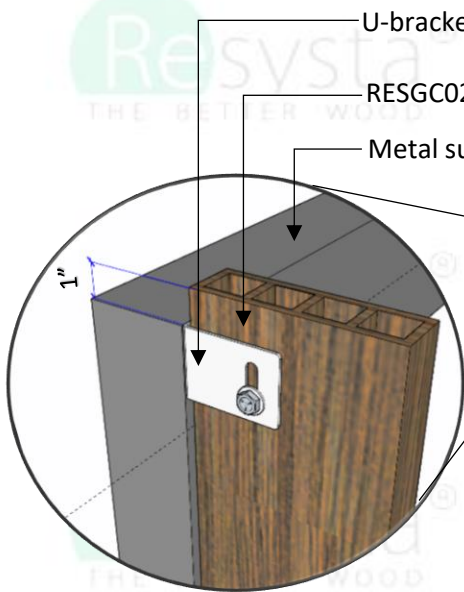

U-bracket with bolt & nuts  
RESGC020616N  
Metal support

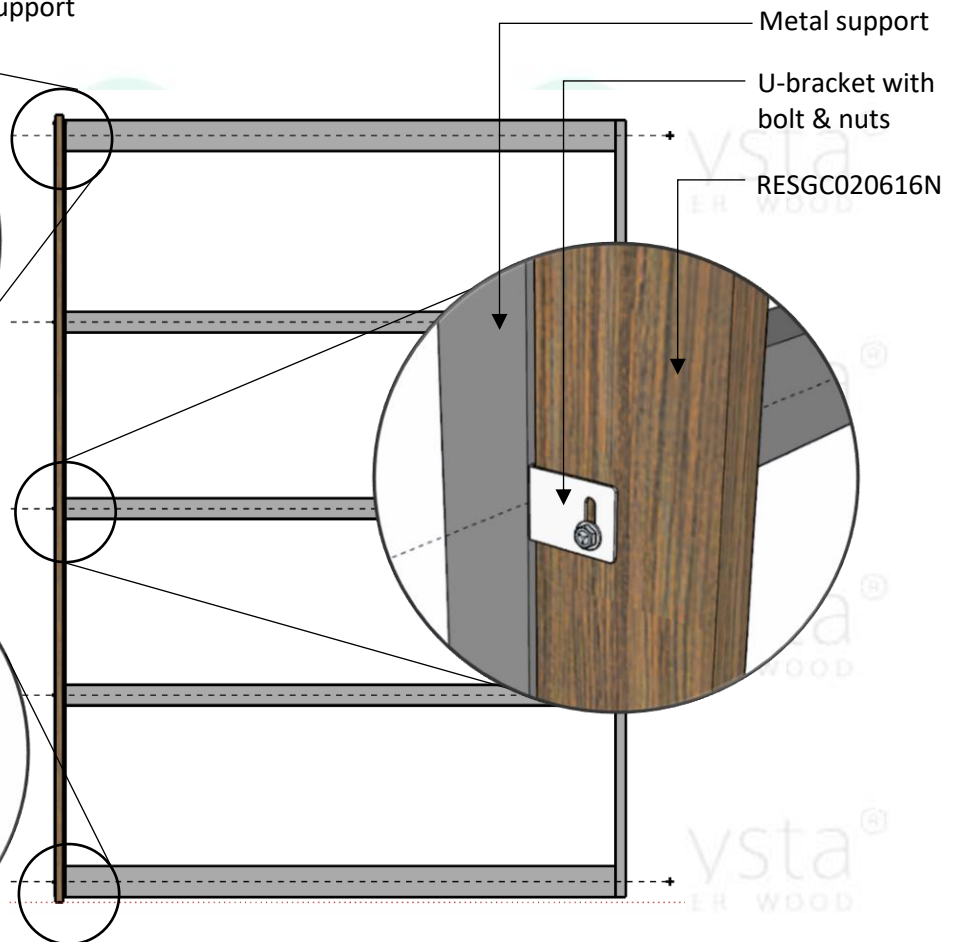
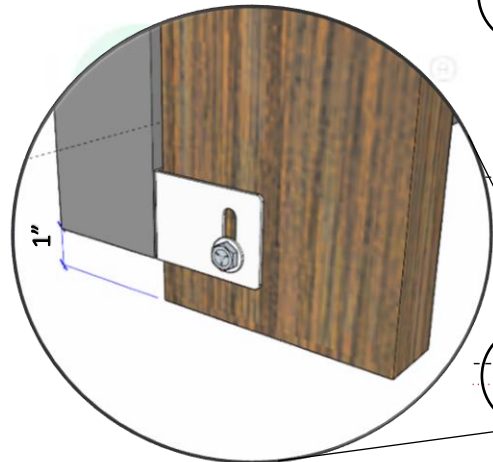

Metal support  
U-bracket with bolt & nuts  
RESGC020616N

**FRONT ELEVATION**

**Please note optional End Cap Details**

- If the profile is to be closed both ends.

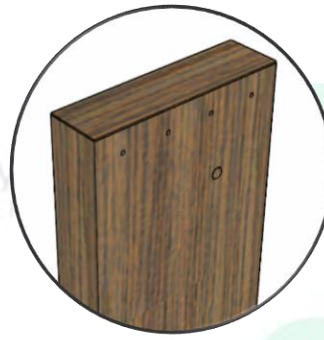

**ISOMETRIC VIEW**  
Top End Cap

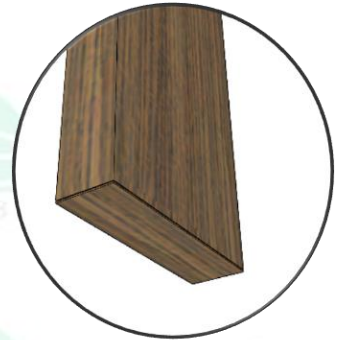

**ISOMETRIC VIEW**  
Bottom End Cap

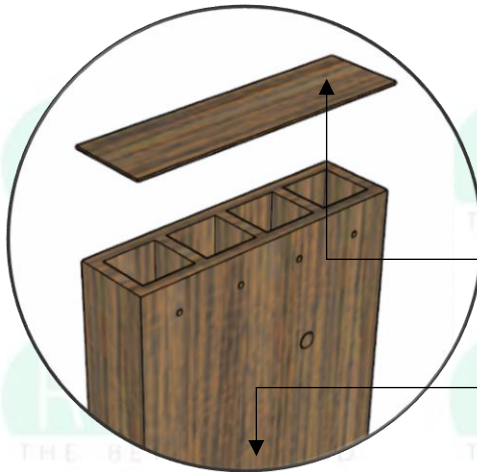
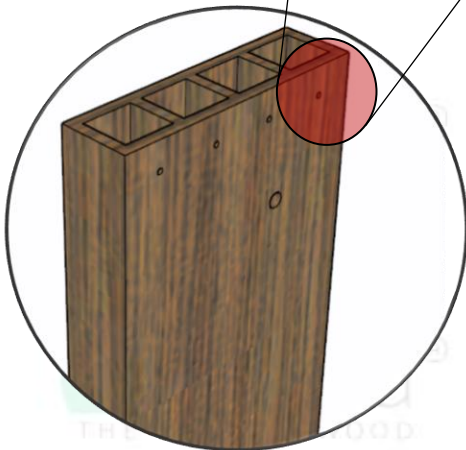
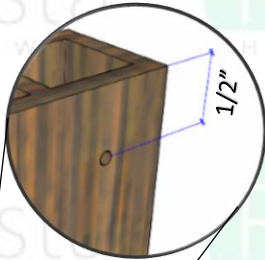

RESCAP0206Cxx

RESGC020616N

1-On one side of the profile need to drill and provide 1/8" diameter hole for every chamber for ventilation.

2-The End cap has a double-sided tape to stick on the profile.

2.6 Repeat steps 2.4 and 2.5, providing enough space to each and every U-bracket and RESGC020616N until reaching the end of the metal support.

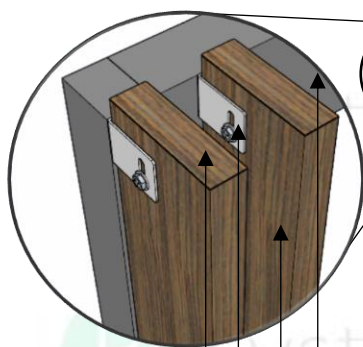

RESCAP0206Cxx

U-bracket with bolt & nuts

RESGC020616N

Metal support

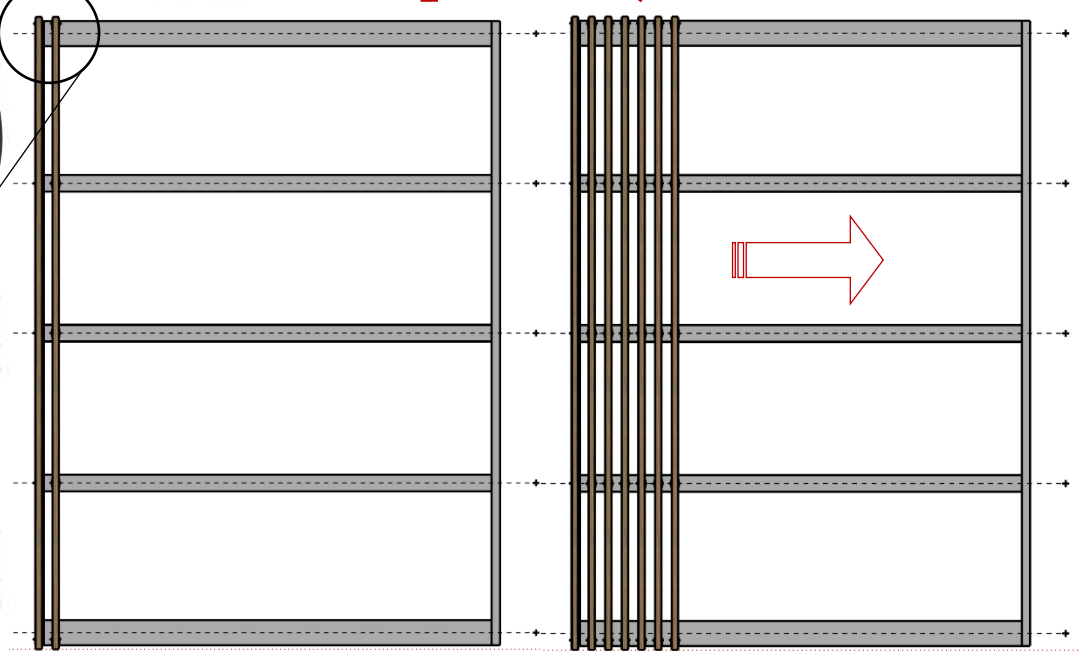

**FRONT ELEVATION**

**FRONT ELEVATION**

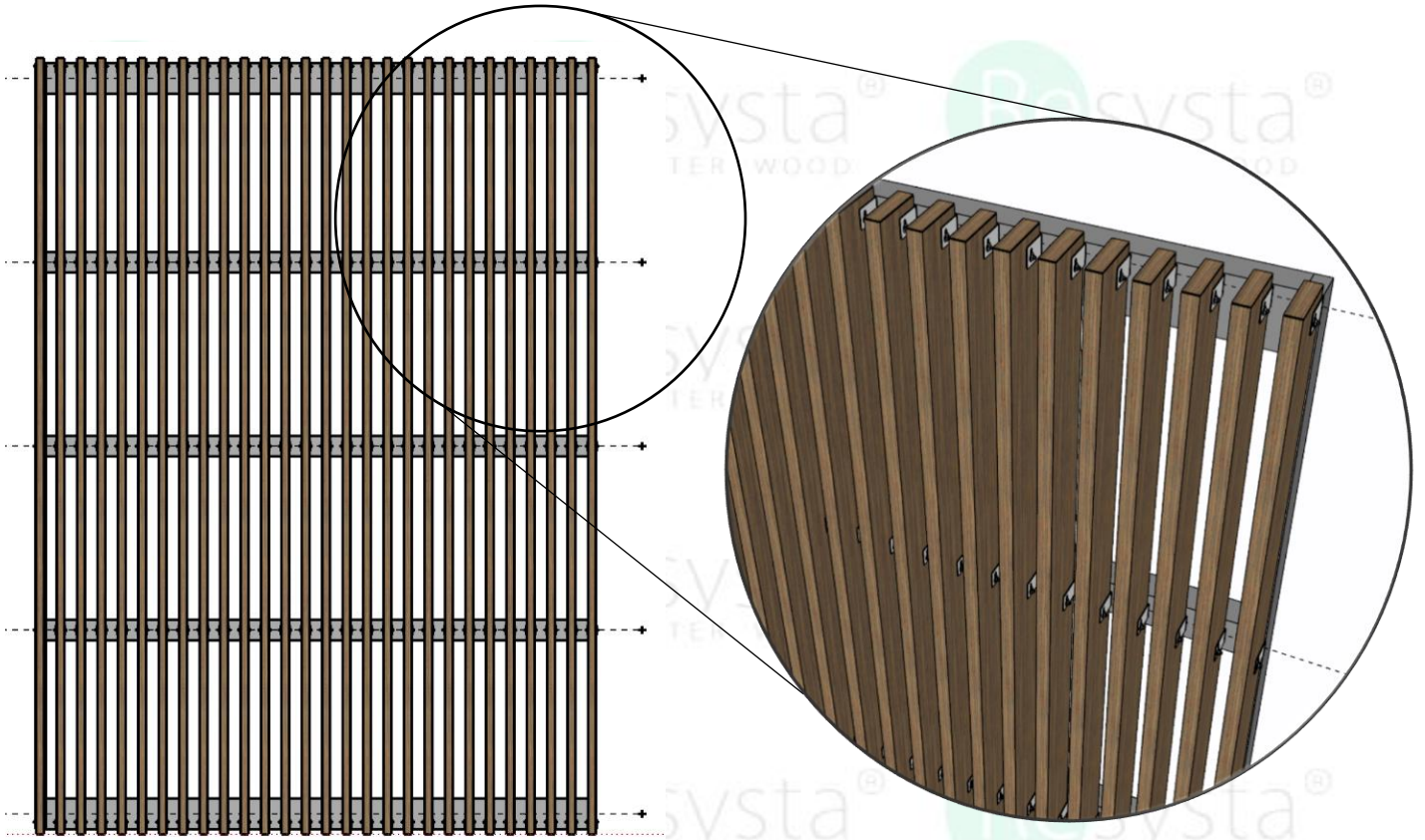

**FRONT ELEVATION**





**B. PROCEDURES for RESGCI020616N and RESGCI11223412 with Metal Insert :**

- 2.1 Check the layout and designed direction of the cladding to be installed; whether it is horizontal, vertical or depends on the design requirements.
- 2.2 Ensure that the metal support is 100% levelled and plumb before installing the aluminium U-bracket on the metal support.
- 2.3 Establish the gridline of the metal support with a maximum 72" center to center of each horizontal support before installing the U-bracket.

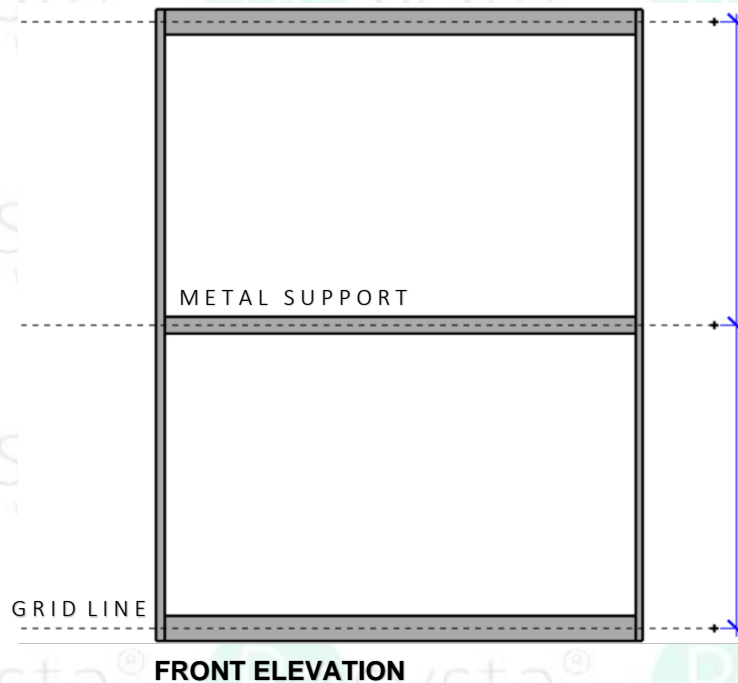

- 2.4 Install the first U-bracket at the corner end of vertical metal support followed by a U-bracket in every 72" center of horizontal metal support.

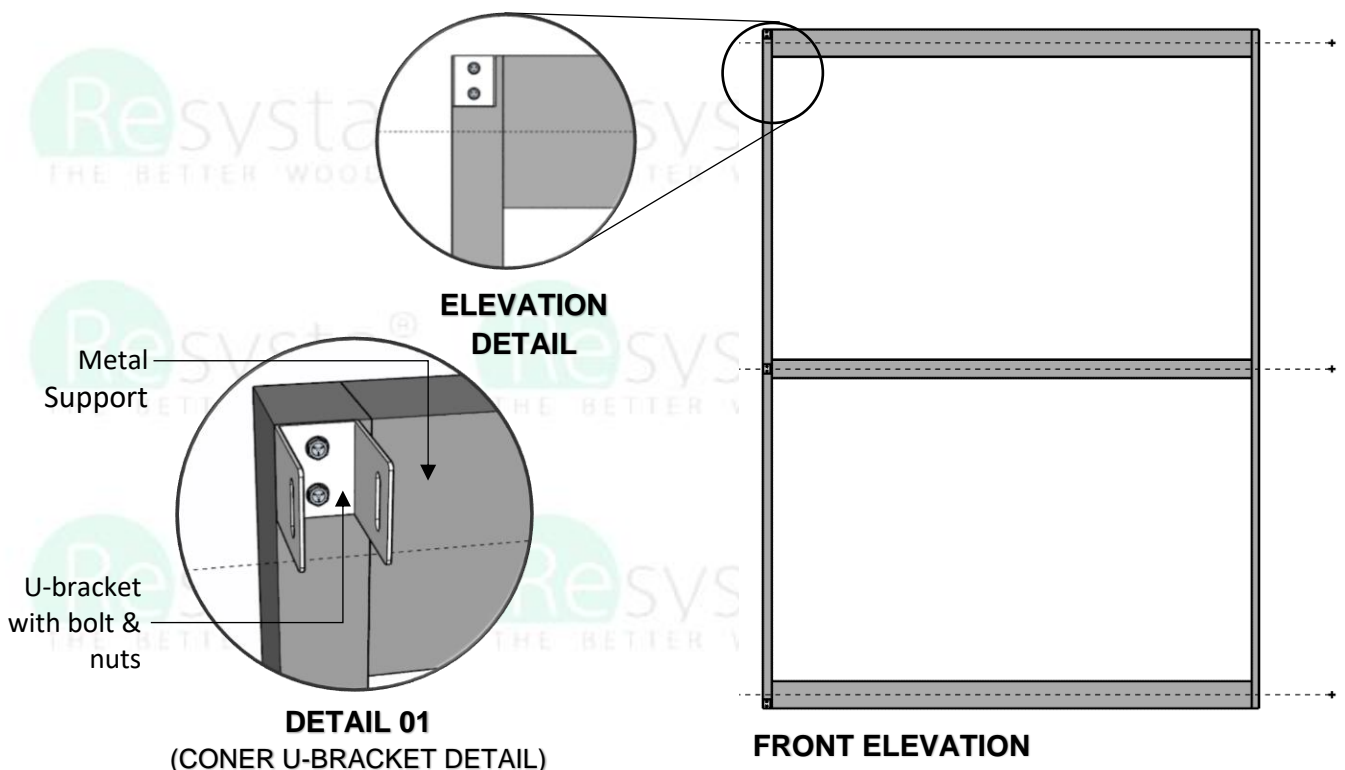

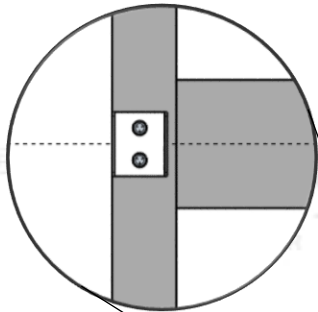

**ELEVATION DETAIL**

Metal Support

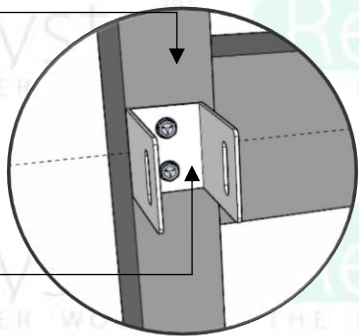

U-bracket with bolt & nuts

**DETAIL 02**

(MIDDLE U-BRACKET DETAIL)

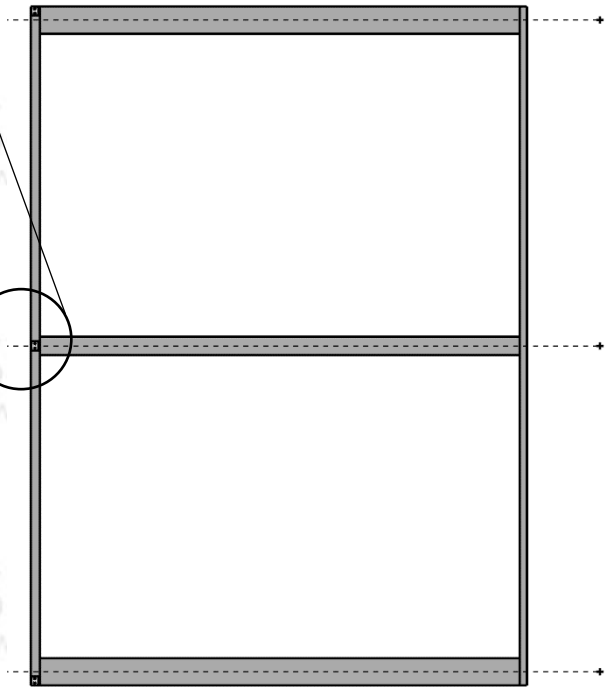

**FRONT ELEVATION**

2.5 Slide the RESGCI020616N into the U-bracket and install the bolt with washer and nut to secure the Resysta profile. Provide an overhang of 1" on top and bottom of the RESGCI020616N profile.

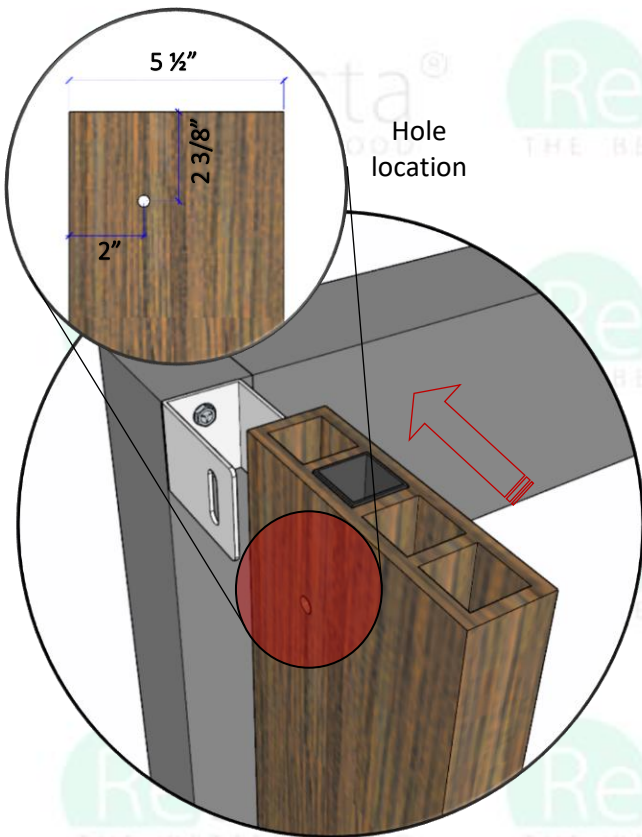

Hole location

1-Drill and provide a 1/2" diameter hole for the first location of bolt with washer and nut.

Metal support  
RESGCI020616N  
U-bracket with bolt & nuts

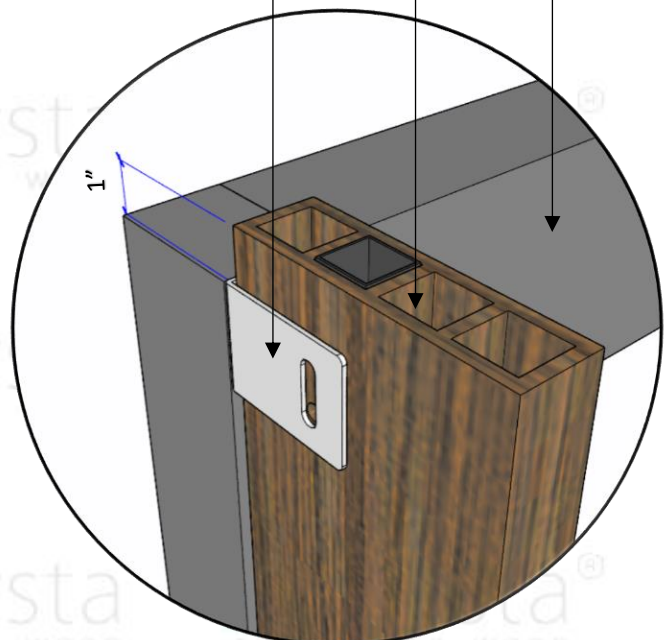

2-Slide the RESGCI020616N Resysta profile into the U-bracket with an overhang clearance of 1" on top of the RESGCI020616N profile.

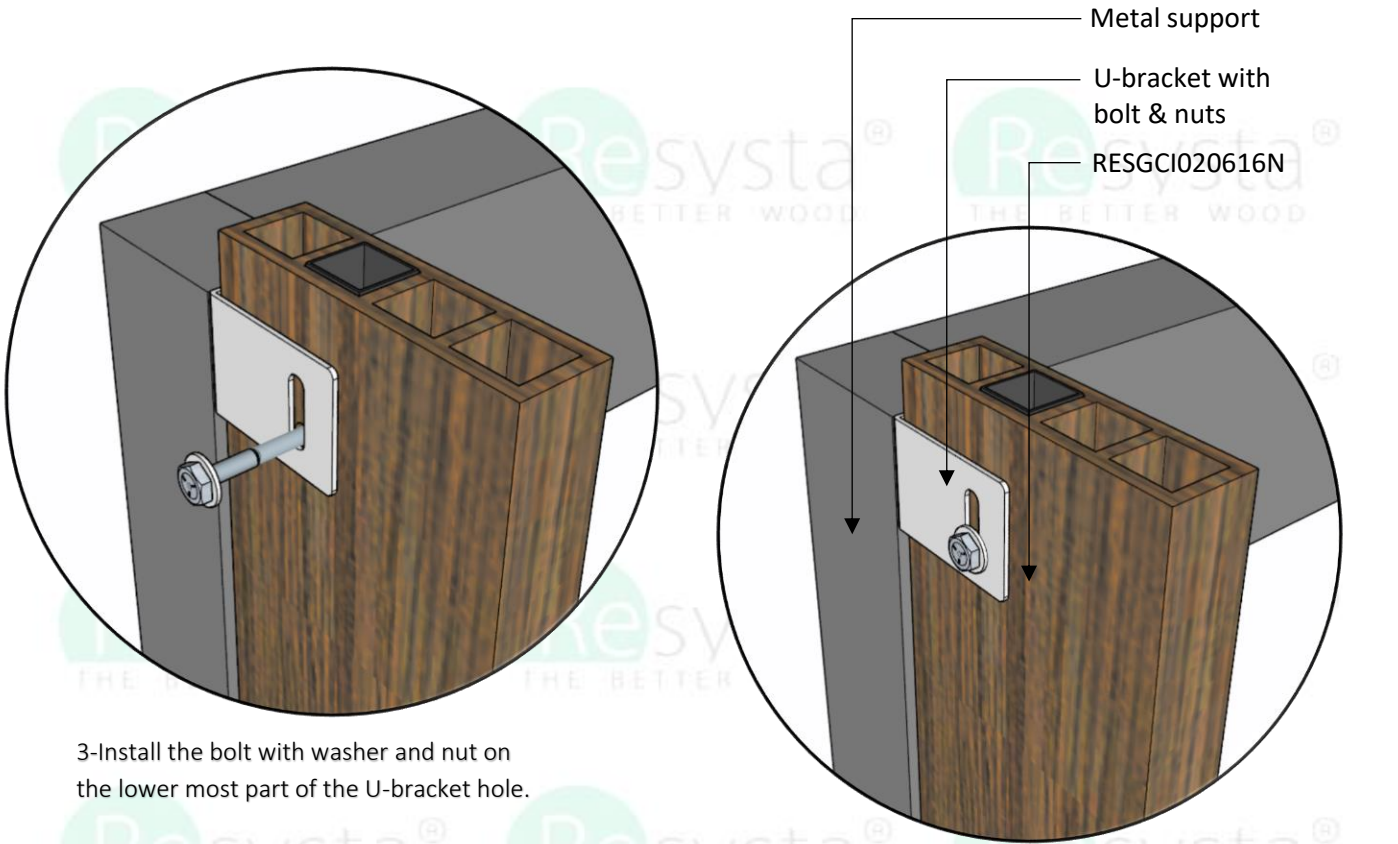

3-Install the bolt with washer and nut on the lower most part of the U-bracket hole.

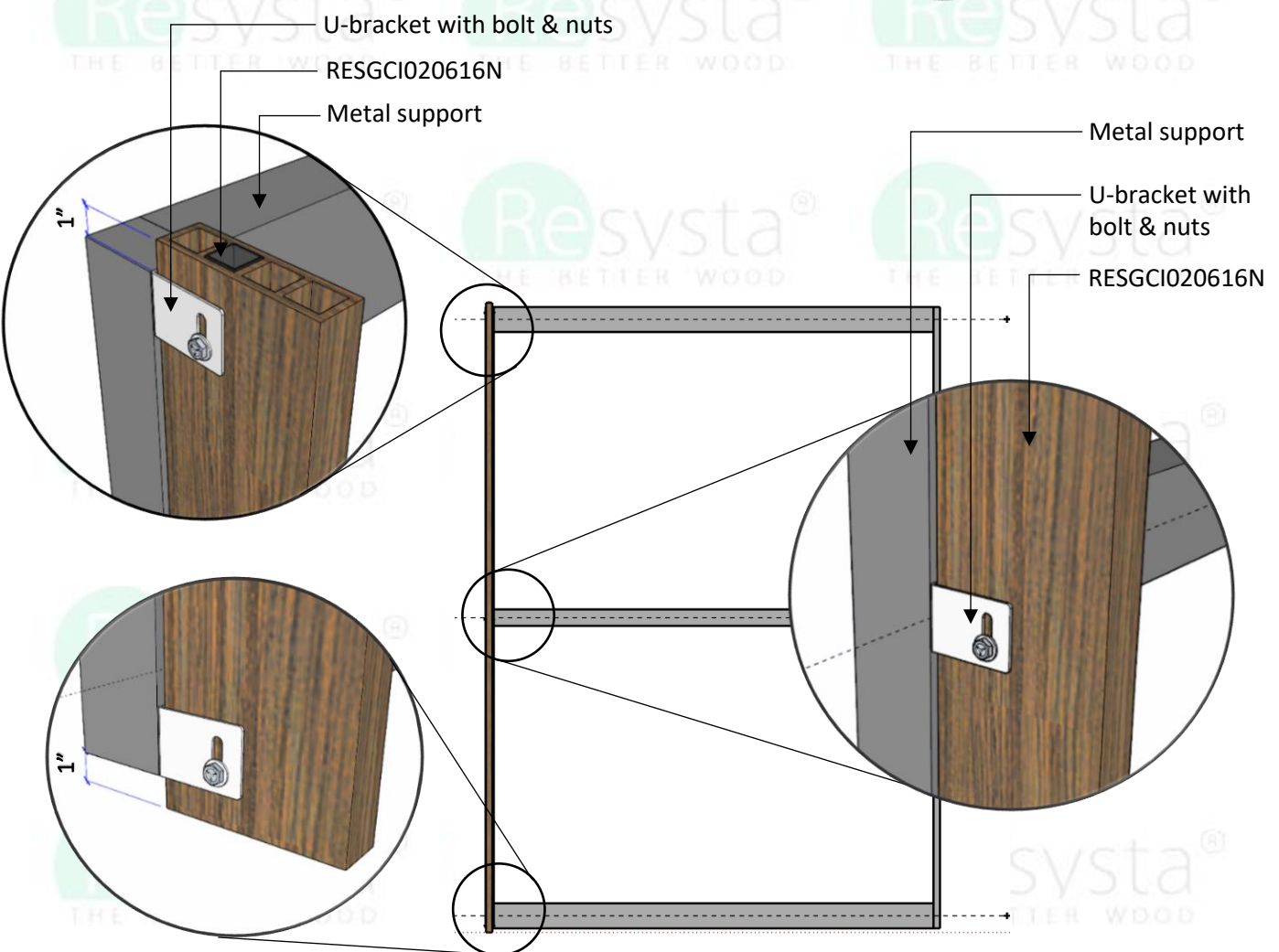

**FRONT ELEVATION**

Please note optional End Cap Details

- If the profile is to be closed both ends.

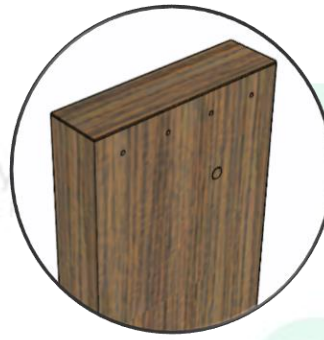
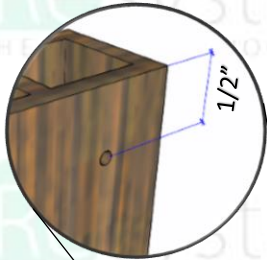

**ISOMETRIC VIEW**  
Top End Cap



**ISOMETRIC VIEW**  
Bottom End Cap

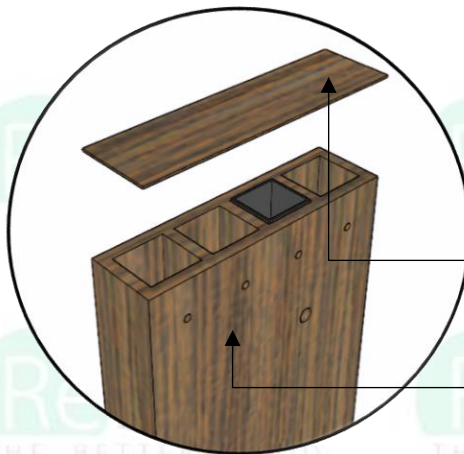
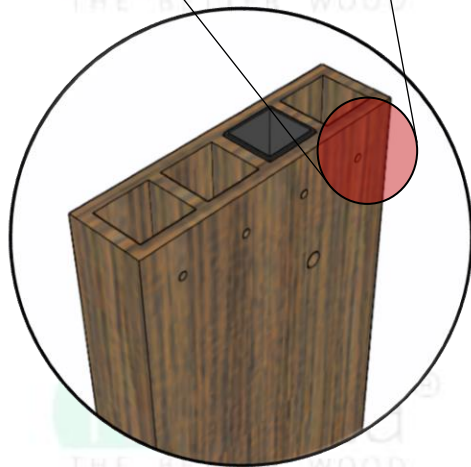

RESCAP0206Cxx

RESGCI020616N

1-On one side of the profile need to drill and provide 1/8" diameter hole for every chamber for ventilation.

2-The End cap has a double-sided tape to stick on the profile.

2.6 Repeat steps 2.4 and 2.5, providing enough space to each and every U-bracket and RESGCI020616N until reaching the end of the metal support.

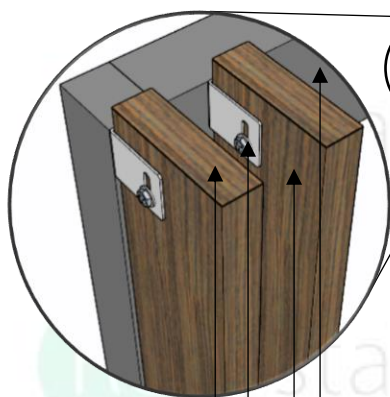

RESCAP0206Cxx

U-bracket with  
bolt & nuts

RESGCI020616N

Metal support

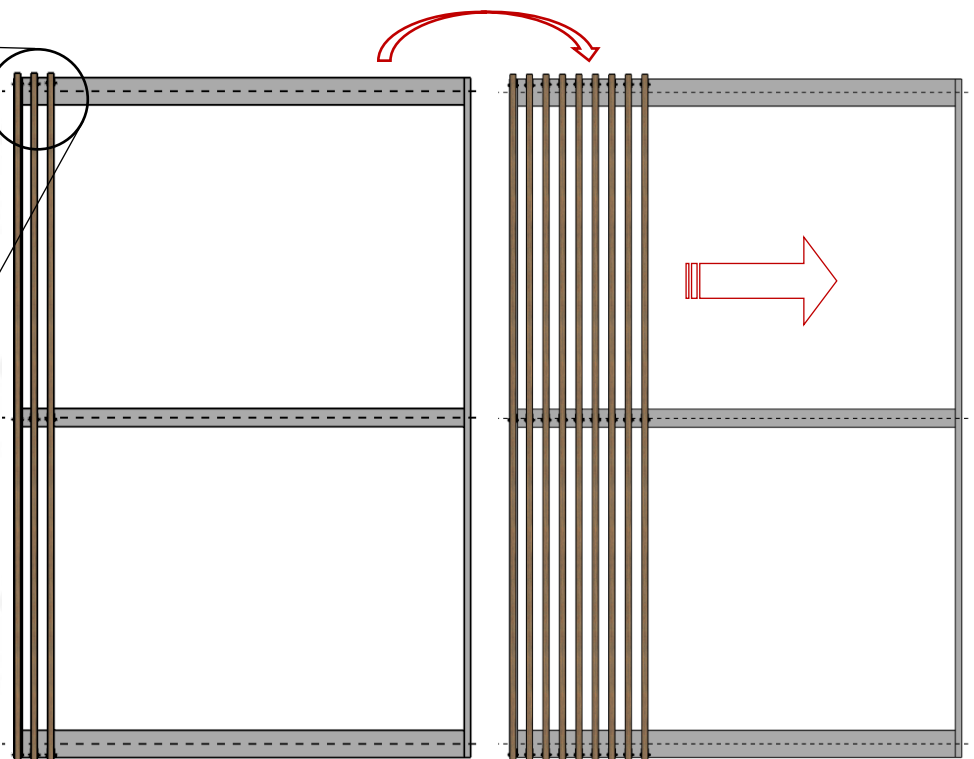

**FRONT ELEVATION**

**FRONT ELEVATION**

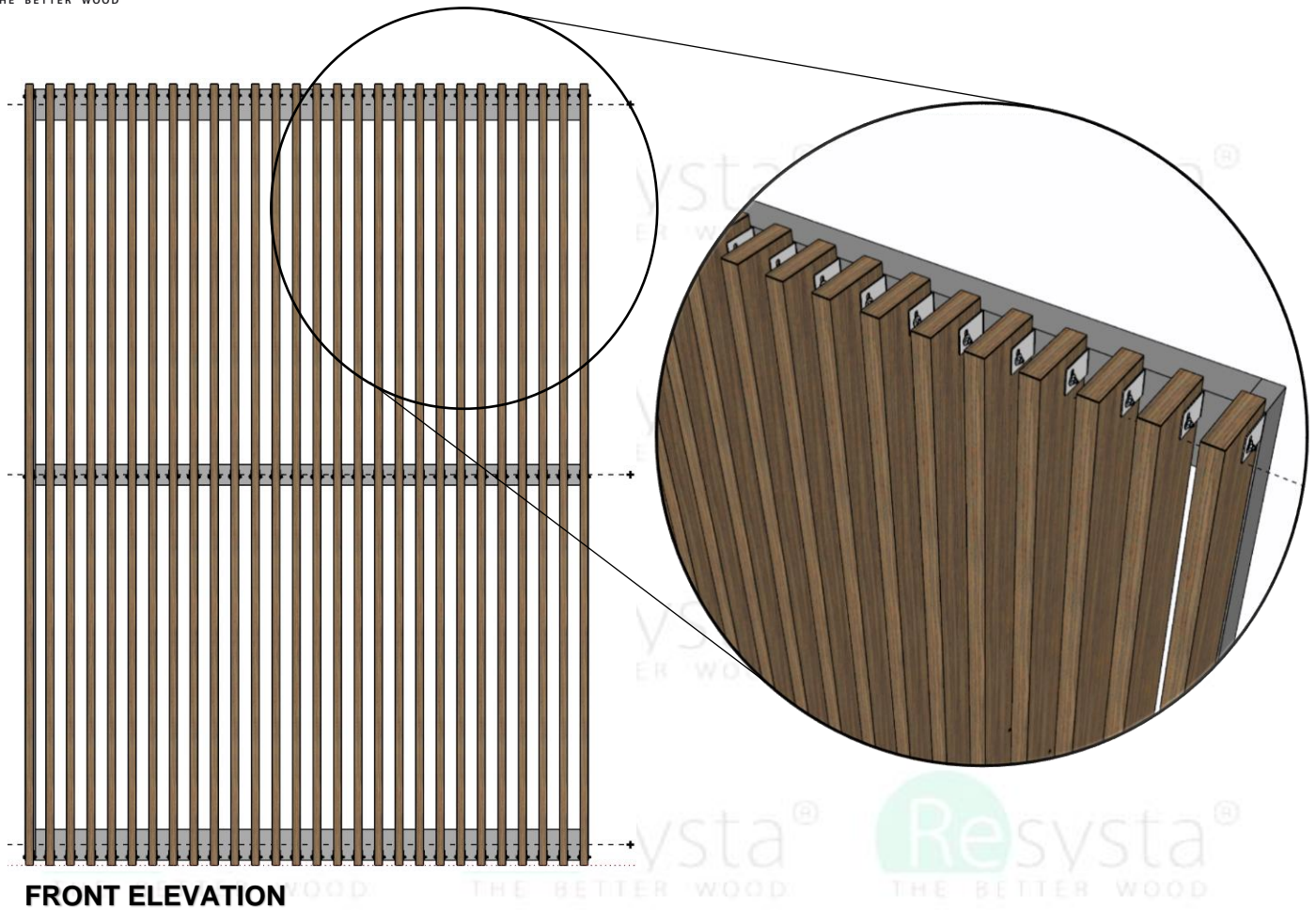

### 3. General Advice

#### 3.1 Expansion Joint

Expansion joint caters for temperature- dependent linear expansion of 1mm gap per board every 10 degrees in temperature change between the ends of the planks. e.g. 2.90m plank= approx. 3mm distance. If the planks are installed closed to a wall the distance here should be 10mm. (Refer to expansion chart)

**Table 1.1**

Surface Temperature	Gap (9 1/2' board)	Gap (12' board)	Ending
30°C- 40°C	1/16"	1/8"	½"
15°C- 30°C	1/8"	3/16"	½"
40°C- 60°C	1/16"	1/16"	½"
60°C- 70°C	none	none	3/16"

3.1.1 The Dimensional change of Resysta is solely dependent on the thermal expansion. Air, humidity and water have no influence on dimensional change. Thermal expansion must be considered at installation.

- 3.1.2 Cutting to length should be carried out at consistent material temperature. Therefore, the materials should be stored in the shade or in areas where it is not exposed to direct sunlight. The material can warm up considerably in the sun, leading to an increased change in length. In the case of more distinct fluctuations in material temperature, cutting to length may have to be adapted accordingly.
- 3.1.3 Resysta has a high vapor diffusion resistance. Please consider at installation.
- 3.1.4 Resysta has a class A fire rating (ASTM-E84).
- 3.1.5 Cut-off pieces and/or abrasive dust have to be disposed separately. Please comply with regulations of your competent waste management. You may under no circumstances burn Resysta yourself.

### **3.2 General Notes**

- 3.2.1 Resysta building products is not responsible for information shown on all details beyond specification scope of work BID/quoted and as indicated contract documents.
- 3.2.2 Details of adjustment work are shown for completeness only. The project Architect / Project Engineer / Erecting Contractor supplying and/or installing the structural support is responsible for its design/installation to accommodate all loads imposed upon the products.
- 3.2.3 Our Engineer is limited to the load carrying components of the siding system and its fasteners shown on the subsequent drawings. The components are supplied by other parties.
- 3.2.4 These drawings are the copyright property of Resysta Building Products, Inc.
- 3.2.5 Please read our installation and design recommendation documents for further information that may be important for your specific project or installation.
- 3.2.6 Ensure a steady material temperature when cutting the boards to size. The cutting has to be done under constant conditions. e.g. inside or in shade.
- 3.2.7 Always consider the linear expansion of Resysta, which is dependent on the temperature but not air humidity. See Table 1.1 for more information.
- 3.2.8 Only use construction fastening material and hardware suitable for outdoor use (e.g. Stainless Steel Screws).

### **3.4 Disclaimer**

Resysta Deco Cladding has been specially developed for their named application and are not a structural material. The items have no general technical approval and are therefore not suitable for supportive construction purposes. Local building codes as well as installations and technical information should be considered. Resysta products should be stored on a flat and level surfaces. If planks are stored on stickers/slats ensure that there is a distance of no more 12" between them. The Resysta cladding must be installed by an authorized professional installer.

For more details please visit our web site <https://www.resystausa.com>